

AIRTECH

Installation
and
Operating Manual

CENTRAL VACUUM SYSTEM - ORION DRY

INSTALLATION & OPERATING MANUAL
ORION-DRY CENTRAL VACUUM SYSTEMS

TABLE OF CONTENTS

1	SAFETY PRECAUTION AND WARNINGS	4
2	SPECIFICATIONS	
	A. GENERAL SYSTEM DESCRIPTION	4
	B. CONTROL FEATURES	4
	C. SEQUENCE OF OPERATION	6
	D. DEVICE OPERATION	6
3	INSTALLATION	
	A. UNCRATING	7
	B. MOUNTING OF UNIT	7
	C. ELECTRICAL REQUIREMENTS	8
4	START-UP	
	A. PREPARATIONS PRIOR TO START-UP	8
	B. FACTORY START-UP	8
5	MAINTENANCE	
	A. SCHEDULE OF MAINTENANCE WORK	
9		
	B. TROUBLESHOOTING GUIDE	9

NOTE: THIS OPERATION AND MAINTENANCE MANUAL IS A GENERAL GUIDELINE FOR ORION DRY CENTRAL VACUUM SYSTEMS AND SHOULD BE USED IN CONJUNCTION WITH SPECIFIC MANUALS FOR THE SUPPLIED VACUUM PUMP ALONG WITH AS BUILT WIRING DIAGRAMS.

1 SAFETY PRECAUTIONS AND WARNINGS

Listed are some, but not all safety precautions that must be observed with pumps and vacuum pump systems. Failure to follow any of these warnings may result in severe personal injury, death, property damage and/or pump damage.

- Disconnect all power supplies to the pump plus any remote controllers prior to servicing the unit per OSHA 1910.147 Lockout/Tagout (Reference Page 16).
- Relieve all internal vacuum from the pump and tank prior to servicing.
- Never use a flammable or toxic solvent for cleaning the air filter or any parts,
- Do not attempt to service any part while the pump is operating.
- Do not operate the pump at pressures in excess of its rating.
- Follow all maintenance procedures and check all safety devices on schedule.
- Never disconnect or tamper with any safety devices.
- Vacuum can be dangerous and should be treated accordingly.

2 SPECIFICATIONS

A. GENERAL SYSTEM DESCRIPTION

The basic design of a vacuum pump system includes the following items: one or more pumps, one receiving tank and one control panel. In most cases, these three items are mounted onto a support base; however, in smaller units the pump may be mounted directly to the tank to conserve space.

The design of the rotary vane vacuum pump is based on the current NFPA codes for medical vacuum systems.

Medical vacuum systems are configured into duplex and triplex systems with redundancy in mind. The backup unit allows maintenance personnel to work on either unit without shutting the system completely down.

Each pump is manifolded together into a large receiver or storage tank. The tank is sized large enough to serve as a reservoir of air for this entire facility system. The facility system is supplied from the tank and not directly from the pump. The vacuum in the tank is maintained at a higher level than the required operating pressure for the facility system.

B. CONTROL FEATURES

AUTOMATIC START-STOP (STANDARD 5HP & DN)

Automatic start-stop operation is accomplished by using the system control switches. Under

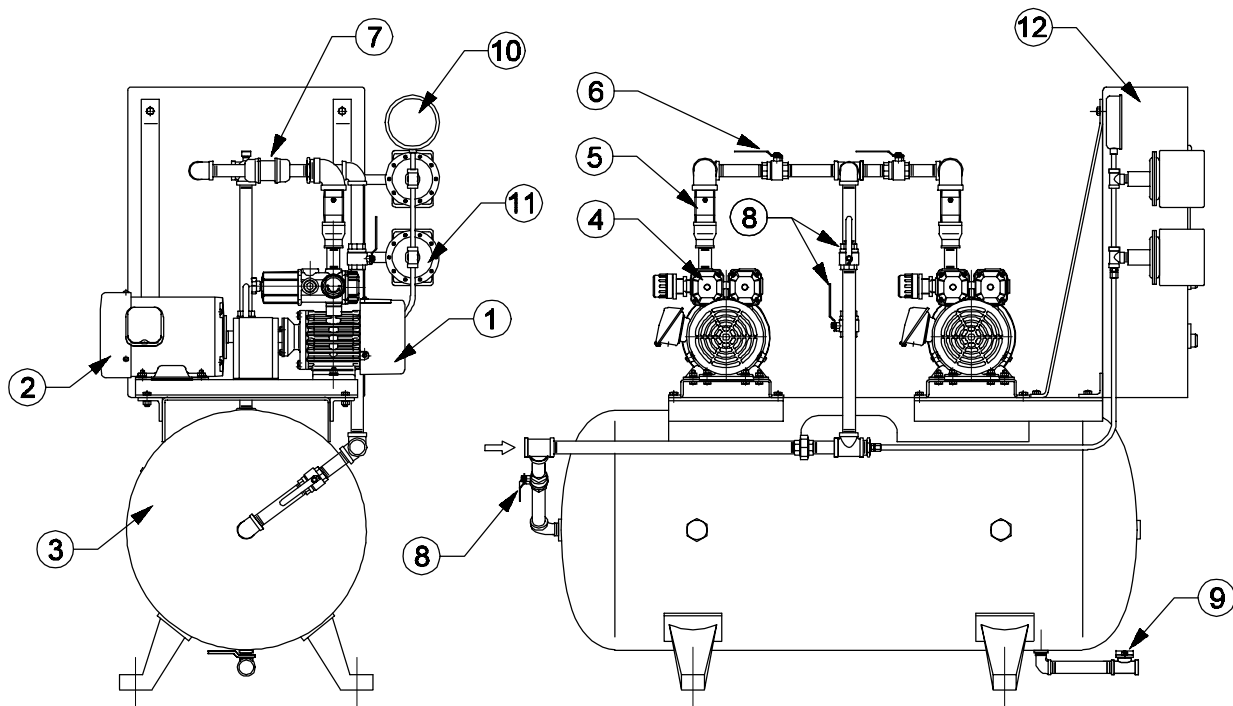

Item	Description	Item	Description
1	Vacuum Pump	7	Flexible Coupling
2	Motor	8	Tank 3 Valve By-pass
3	Tank	9	Tank Drain Valve
4	Inlet Filter	10	Vacuum Gauge
5	Inlet Check Valve	11	Vacuum Switch
6	Pump Isolation Valve	12	Motor Control Center

normal operation with the selector HOA switch in the “AUTO” position, the “LEAD” vacuum pump will start when the system is not satisfied. (**Note:** Use “HAND” position of the selector switch only for testing.)

Should one pump not satisfy the system, the “LAG” pump will start automatically upon system demand increase and activate the lag alarm.

Automatic alternator will switch the “LEAD” position to the next pump every time after the lead pump has shut down.

AUTO DUAL CONTROL (STANDARD 7.5HP & UP - OPTIONAL 5HP & DN)

Auto dual control is accomplished by using the system control switches and time delay called “Minimum Run Timers” incorporated in the control panel. This feature is also referred to as “Controlled Time Run” or “CTR”.

This arrangement prolongs the lifetime of the motors, preventing them from frequent starting and stopping (cycling) by allowing them to run for a minimum predetermined period of time.

If during this period of time the system has not been satisfied, the pump(s) will continue to run and will shut down only when the control switch opens.

If the control switch opens before the minimum run time has elapsed, the vacuum pump(s) will continue to run. If the control switch recloses before the minimum run time has elapsed, the pump(s) will then reload.

If there is no system demand and control switch stays open, the pump(s) will shut-down after "minimum run time" has elapsed.

AUTOMATIC ALTERNATOR (STANDARD)

Automatic alternator will switch the "LEAD" position to the next pump every time after the lead pump has been shut down.

Should a "LEAD" pump not shut down for an extended period of time, the time clock override will switch the "LEAD" position to the next pump after 30 minutes.

C. SEQUENCE OF OPERATION

During normal operation, the "LEAD" pump starts and stops to satisfy air demand. The starting and stopping of the lead pump is determined by the "CUT-IN" and "CUT-OUT" settings of the lead vacuum switch. When demand is exceptionally heavy, or there is a failure of the lead pump, the "LAG" pump will start and operate at its predetermined cut-in and cut-out settings. The system includes as standard a "LAG-ON" alarm, as required by NFPA, to provide local audible and visible alarm, as well as connection points for wiring to a remote indicator.

D. DEVICE OPERATION

HIGH AIR TEMPERATURE SWITCH (OPTIONAL)

High air temperature switches are provided for each individual pump. The switch will shut down the affected pump upon a pre-determined high discharge air temperature. Standardly included are both audible and visual local alarms as well as connections for remote indicator. Re-set button for each switch is located at the switch itself. Switches have an adjustable set point.

HOUR METERS (STANDARD)

Utilized to indicate the actual running time of each pump. Hour meters are especially useful in scheduling maintenance procedures.

SITE GLASS (OPTIONAL)

Utilized for visual inspection of condensate level in air receiver. Where glass clouds and makes inspection difficult, either clean or replace glass. Isolation valves are included for this purpose.

RECEIVER THREE VALVE BYPASS (STANDARD ON MEDICAL SYSTEMS)

Utilized to isolate receiver from system when required.

3 INSTALLATION

A. UNCRATING

RECEIPT OF UNIT

Before uncrating the vacuum system the following steps should be taken:

1. Immediately upon receipt of the equipment, inspect for damage that may have occurred during shipment. If any damage is found, demand an inspection immediately from the carrier. **Shipping damage is not covered by the Airtech Inc. warranty.**
2. Insure that adequate lifting equipment is available for moving the machinery.
3. Read the vacuum pump and electrical motor nameplates to be sure the vacuum system is the model and size ordered.
4. Read the motor nameplate to be sure the motor is compatible with your electrical conditions (Volts-Phase-Hertz). Also note whether the motor is suitable for the expected environmental conditions.

REMOVING CRATE

Remove crate carefully and dispose of properly. During crate removal, protect unit against damage from uncrating tools. If unit is to remain uninstalled on jobsite for a period of time, it is recommended that the unit remain crated to protect against damage.

LONG TERM STORAGE

In instances where the unit is to be stored for a lengthy period prior to installation and operation, it should be located in clean, cool, dry area protected from the elements. Special care must be taken with the control panel to ensure it is protected from dust and moisture. All pipe openings should be capped accordingly. This applies to all vacuum pumps shipped to the jobsite. Keep them free of construction debris and do not allow workmen to use them as ladders or platforms for work above.

B. MOUNTING OF UNIT

LOCATION

Locate the vacuum system in an area that is clean, well lighted, and well ventilated, with sufficient space for safe and proper inspection and maintenance. The pump is capable of operating in an ambient temperature up to 104° F provided that the area is well ventilated. In cold climates, the pump should be installed in a heated building (32° F or above). Inspection and maintenance checks are required daily. Therefore, sufficient uncluttered space needs to be provided around the system. The system should not be installed closer than twenty-four (24) inches to a wall to allow ample circulation of air across the pump.

MOUNTING

The installation requires a flat and level concrete floor pad. Satisfactory results can usually be obtained by mounting the unit on vibration pads available from Airtech Inc. On tank mounted packages, make absolutely certain the receiver tank feet are not stressed in any manner. Severe vibrations can result when feet are uneven and drawn tightly to the pad which can lead to welds cracking or fatigue failure of the receiver.

C. CONNECTION TO SERVICES

PIPING

Care must be taken in assembling piping to or within the vacuum system. It should line up without having to be pulled into position. Adequate expansion loops or bends should be installed to prevent undue stresses at the system resulting from the changes between hot and cold conditions. Pipe supports should be mounted independently of the system and anchored as necessary to limit vibration and prevent expansion strains. Proper pipe size is necessary to maintain proper operating pressures.

ELECTRICAL

Before installation, the electrical supply should be checked for adequate wire size and transformer capacity. Where a 3 phase motor is used to drive a pump, any unreasonable voltage imbalance between the legs must be reduced and low voltage corrected to prevent excessive current draw. The installation, electric motor, wiring and all electrical controls must be in accordance with NFPA70-1984 National Electric Code, National Electric Safety Code, state and local codes. All electrical work should be performed by a qualified electrician. Failure to abide by the national, state and local codes may result in physical harm and/or property damage.

4 START-UP

A. PREPARATIONS PRIOR TO START-UP

Preparation should be made prior to start-up to ensure that the entire system may be tested.

1. Mount the vacuum system into its permanent location.
2. The main power source for this system must be made into the control panel.
3. All alarm contacts must be wired into the central alarm system.
4. The exhaust of the vacuum pumps should be run outside and turned down with a wire mesh screen over the opening.
5. The vacuum system must be tied into the facility line.

B. FACTORY START-UP

Where included, a start-up is performed by a factory trained service technician. The start-up will include a performance test on the system to ensure proper operation. For information and scheduling for the start-up, contact the Service Department at Airtech Inc. Scheduling a start-up will require a two week notice.

5 MAINTENANCE

A. SCHEDULE OF MAINTENANCE FOR ROTARY VANE VACUUM PUMPS

Hours/Days (whichever comes first) Check	8 Hrs Daily	40 Hrs Weekly	160 Hrs Monthly	500 Hrs 3 Months	2000 Hrs 12 Months
1 Give system an overall visual inspection and be sure safety guards are in place.	X				
2 Check for any unusual noise or vibration.	X				
3 Check oil level (if applicable).	X				
4 Clean the pump and cooling fins.		X			
5 Inspect and/or replace oil demister filters (if applicable).					X
6 Change oil (if applicable).				X	
7 Check drive condition.				X	
8 Lubricate electric motor.					X
9 Inspect pressure switch diaphragm and contacts. Also contact points in motor starter.					X
10 Inspect and/or replace inlet filter elements.				X	

B. TROUBLESHOOTING GUIDE

This section contains possible solutions to some of the most common problems encountered when working with rotary vane vacuum pumps. Each topic is organized so that the most probable or simplest solution is described first. Although every attempt has been made to be thorough, problems may arise which are not covered. In such case, please call the factory for assistance.

PROBLEM 1: Will not start

1.1 Make sure motor is wired properly. Refer to table of contents for a typical motor wiring diagram.

1.2 The electrical circuit must be properly sized to handle load. Starter and overload device must be sized and set for motor nameplate data. Wiring size must be sufficient to handle motor amperage draw and to overcome voltage drops in long wire runs. Also check that the correct voltage is supplied.

1.3 Motor failure may have occurred. Consult qualified electrician for a determination of this condition.

1.4 The pump or motor may be obstructed in such a way as to prevent turning. To check for this condition, disconnect power supply and remove motor fan cover. Try turning fan by hand. If fan will not turn, remove motor from pump and try turning each separately. Consult factory if pump will not turn. Do not try to force the pump to turn since this could cause further damage. If motor will not turn, consult a qualified electrician for further diagnosis.

PROBLEM 2: Runs excessively hot

2.1 Pump must have adequate ventilation for cool operation. If pump is installed in an enclosure, make sure recirculation of hot exhaust cooling air is avoided and pump receives enough fresh cooling air. Do not block cooling air entrances to pump. Do not allow the pump to become covered with dirt, dust or process material. This will act as an insulator which may severely damage the pump.

PROBLEM 3: Excessive noise level

3.1 The coupling rubber(s) may be worn. Call the factory for replacements.

3.2 The noise may be caused by worn bearings. For replacement parts or service, call the factory.

PROBLEM 4: Pump has seized

4.1 Liquid may have been ingested into pump.

4.2 Process vapor may have condensed inside pump.

4.3 Inlet valve plate assembly may not be functioning properly.

4.4 Pump may have been operated in the wrong direction for an extended period of time.

4.5 Pump may have vane damage.

When calling the factory, have pump model and serial number available.

NOTE: If liquid is found to have been ingested or if process vapor is condensing inside the pump, protective measures must be taken. Install trap or filter device on inlet of pump to remove the contaminate from the air stream.

For further information please contact:

AIRTECH IN}
150 South Van Brunt St.
Englewood, NJ 07631
Tel: 1-888-222-9940
Fax: 201-569-1696
airtech@airtechusa.com

AIRTECH SOUJG
2211 Newmarket Parkway
Marietta, GA 30067
Tel: 770-690-0700
Fax: 770-690-0709
airtechsouth@airtechusa.com

AIRTECH WFSV
42 Digital Drive - #9
Novato, CA 94949
Tel: 415-382-9000
Fax: 415-382-9700
airtechwest@airtechusa.com

www.airtechusa.com