

AIRTECH oil-flooded, multi-vane vacuum pumps are single stage, air cooled and direct driven. This simple design ensures the reliability and the durability that is required in the vacuum industry.

Standard Equipment:

- Composite vane material for long life
- Oil level sight glass
- Vibration isolators
- Anti-suck back valve
- Integral exhaust filters
- TEFC high efficiency tri-voltage motor (208-230/460V 50/60)
- Wire mesh inlet screen

Performance Curves

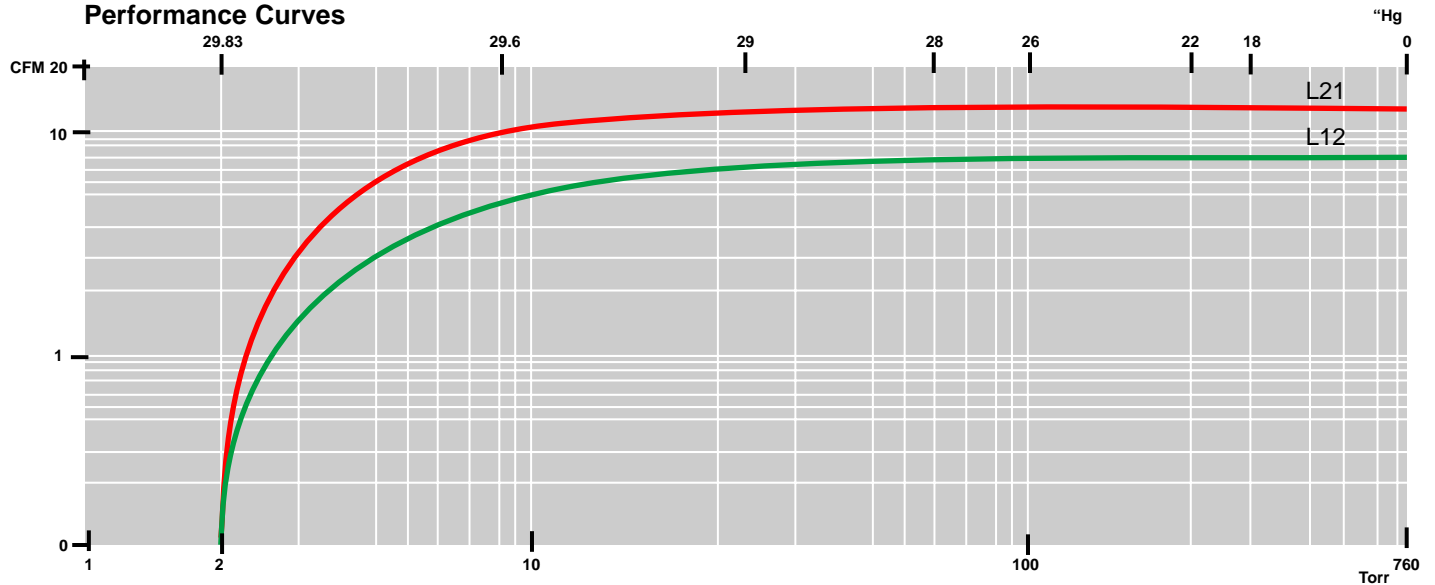

Power Consumption

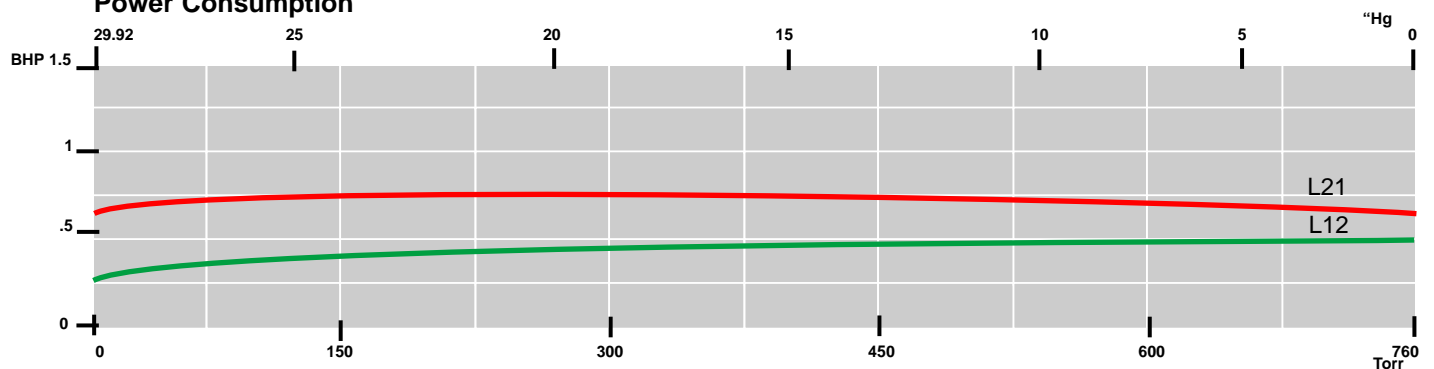

Dimensions (inches):

Specifications are subject to change without notice. Please contact factory for specification updates.

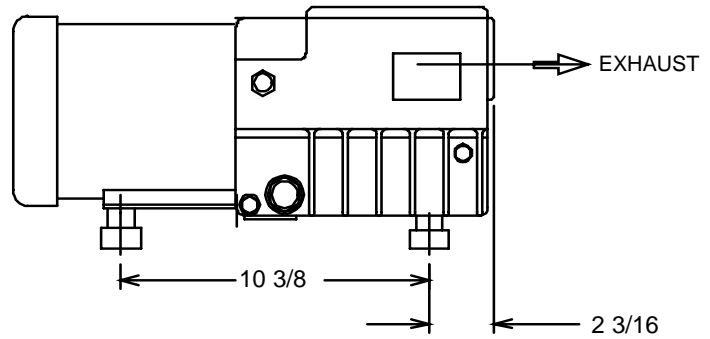
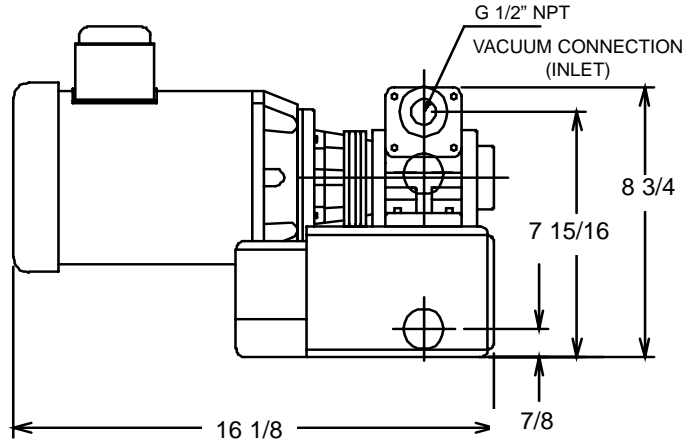
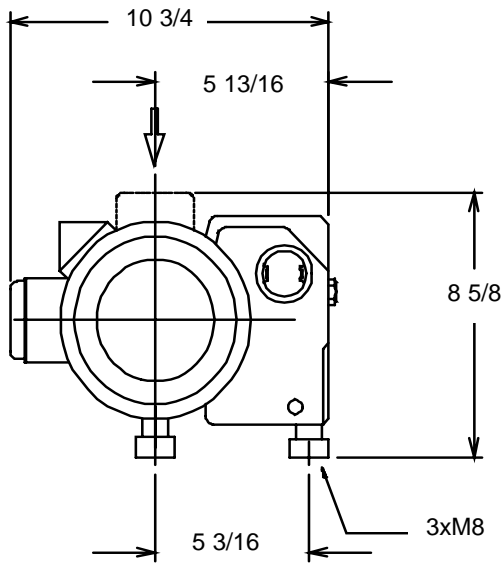

Specifications:

| Model | 12 | 21 |
|-----------------------------------|------|------|
| Free Air Displacement [CFM] 60 Hz | 7 | 15 |
| Motor Capacity [HP] 60 Hz | .75 | 1.0 |
| Speed [RPM] 60 Hz | 1725 | 3450 |
| Sound Level [dB(A)] 60 Hz | 59 | 62 |
| End Vacuum [Torr] | 2.0 | 2.0 |
| Weight [Lbs] [with motor] | 42 | 42 |
| Oil quantity [Qts] | .5 | .5 |