

AIRTECH oil-flooded, multi-vane vacuum pumps are single stage, air cooled and direct driven. This simple design ensures the reliability and the durability that is required in the vacuum industry.

Standard Equipment:

- High Performance Kevlar vane material for long life
- Oil level sight glass
- Vibration isolators
- Anti-suck back valve
- Integral exhaust filters
- TEFC high efficiency tri-voltage motor (208-230/460V 50/60)
- Exhaust pressure gauge
- Wire mesh inlet screen
- Spin-on oil filter

Performance Curves

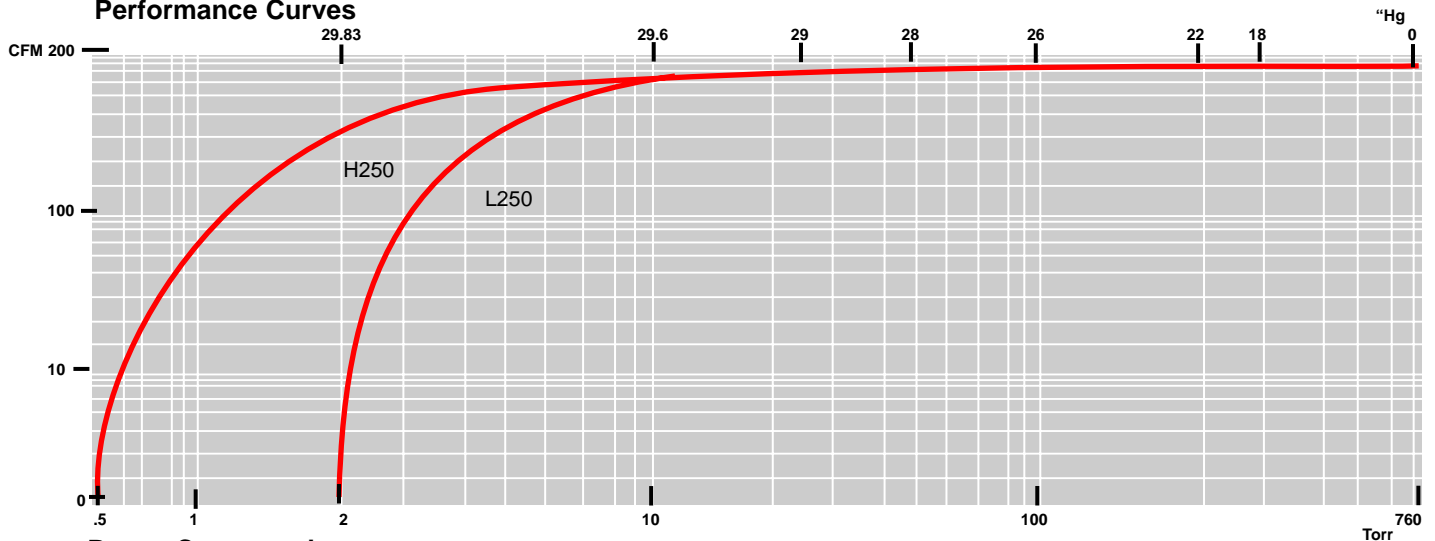

Power Consumption

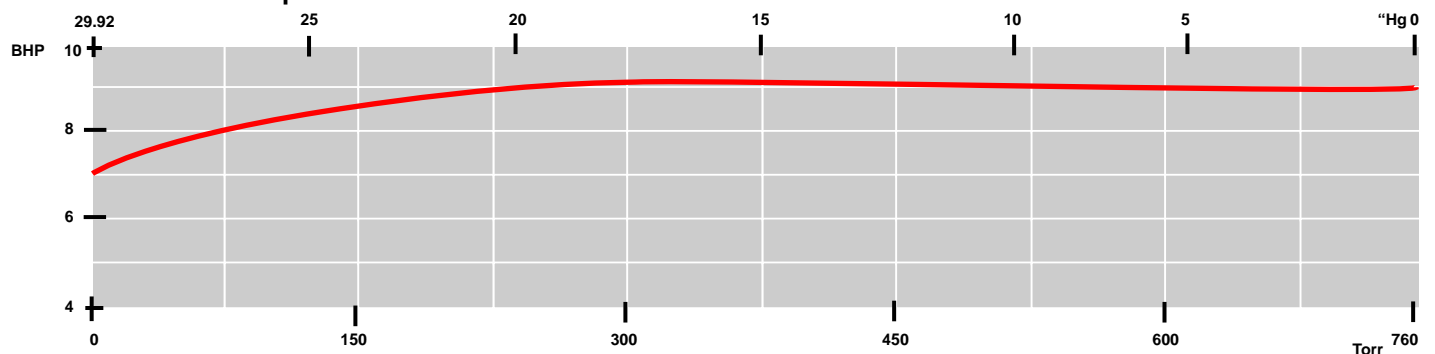

Dimensions (inches):

Specifications are subject to change without notice. Please contact factory for specification updates.

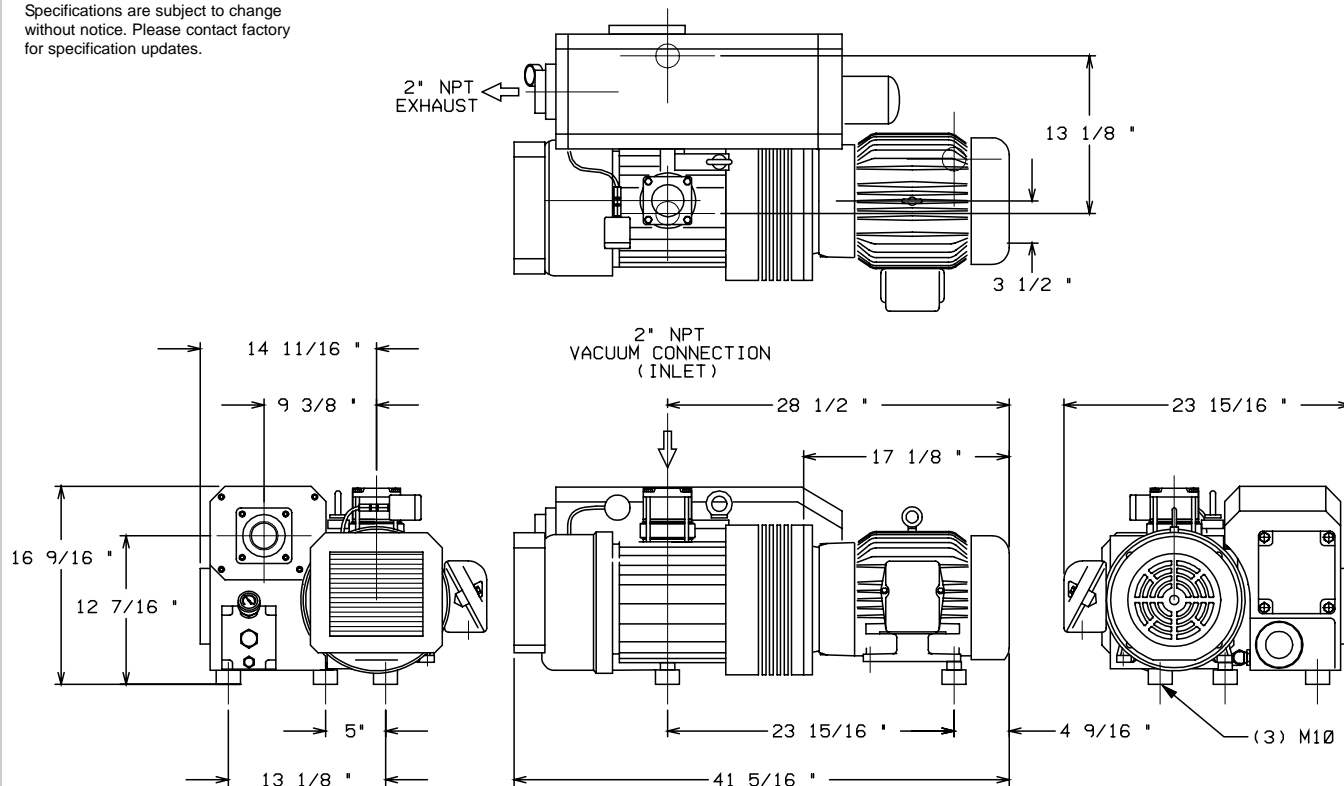

Specifications:

Model	250D
Free Air Displacement [CFM] 60 Hz	180
Motor Capacity [HP] 60 Hz	10
Speed [RPM] 60 Hz	1725
Sound Level [dB(A)] 60 Hz	80
End Vacuum [Torr] -L	2.0
End Vacuum [Torr] -H	0.5
Weight [Lbs] [with motor]	407
Oil quantity [Qts]	7