

Dimensions: (inches)

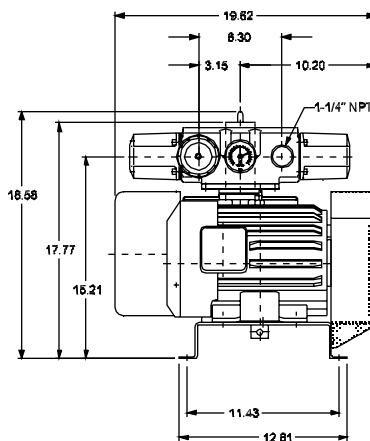
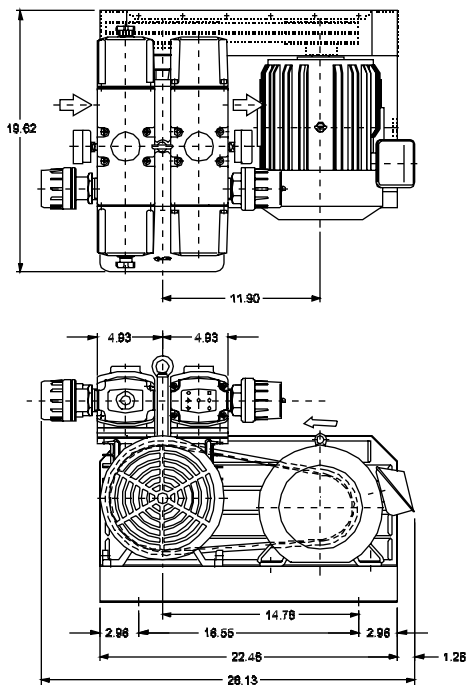

Notes:

- a: Standard voltage for three phase pumps is 208-230/460V 3ph 60Hz.
- b: Standard voltage for single phase pumps is 115/230/1ph 50/60Hz or 115V/1ph 60Hz or 230V/1ph 60Hz
- c: All pumps available in 50Hz frequency and with other voltages.

Specifications subject to change without notice.
Please contact factory for specification updates.

Specifications: (Vacuum)

Model Number	Motor	RPM	HP	CFM	Max. Hg"	LBS	Kgs
KRA10-SP-3701-G3	w/o Motor			75	27.5"	240	109
KRA10-SP-3701-G1	208-230/460V	1200	5	75	27.5"	280	127
KRA10-SP-3702-G1	115/230V	1200	5	75	27.5"	310	141

Specifications: (Pressure)

Model Number	Motor	RPM	HP	CFM	Max. PSI	LBS	Kgs
KRA10-SP-3750-G3	w/o Motor			75	14psig	240	109
KRA10-SP-3750-G1	208-230/460V	1200	5	75	14psig	280	127
KRA10-SP-3751-G1	115/230V	1200	5	75	14psig	310	141