

Dimensions: (inches)

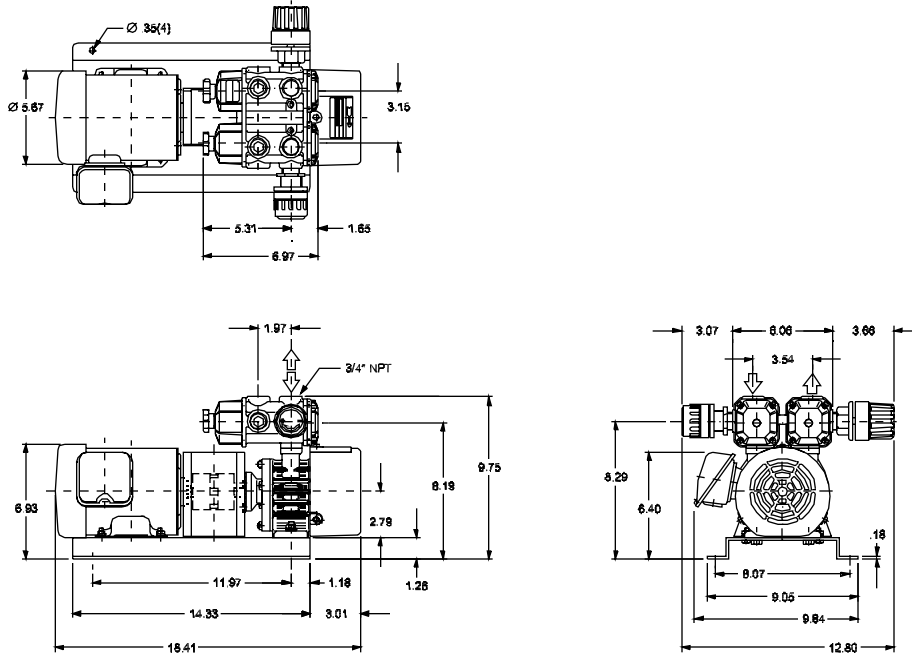

Notes:

- a: Standard voltage for three phase pump is 208-230/460V 3ph 60Hz.
- b: Standard voltage for single phase pump is 115/230/1ph 50/60Hz or 115V/1ph 60Hz or 230V/1ph 60Hz
- c: All pumps available in 50Hz frequency and with other voltages.

Specifications subject to change without notice.
Please contact factory for specification updates.

Specifications: (Vacuum)

Model Number	Motor	RPM	HP	CFM	Max. Hg"	LBS	Kgs
KRX3-SS-4001-G3	w/o Motor			10	27.5"	35	16
KRX3-SS-4001-G1	208-230/460V	1750	0.5	10	27.5"	47	21
KRX3-SS-4002-G1	115/230V	1750	0.5	10	27.5"	47	21

Specifications: (Pressure)

Model Number	Motor	RPM	HP	CFM	Max. PSI	LBS	Kgs
KRX3-SS-4050-G3	w/o Motor			10	14psig	35	16
KRX3-SS-4050-G1	208-230/460V	1750	0.5	10	14psig	47	21
KRX3-SS-4051-G1	115/230V	1750	0.5	10	14psig	47	21