

AIRTECH VACUUM

MEDICAL VACUUM SYSTEMS

NFPA 99C Compliant Medical Vacuum Systems
Tank or Based Mounted Self Contained Liquid Ring (SCLR)
The Airtech 'SCLR' pump can operate 24/7 with minimal
make-up water - less than 4 gallons per hour

*Airtech NFPA compliant Medical Vacuum Systems are manufactured and tested to NFPA 99C standards. Each of our various medical systems utilize only the highest quality components and each system is provided with the following features:

- UL Listed NEMA 12 enclosed motor control center
- UL listed through the door disconnect switches (5.1.3.6.6.3)*
- Individual control transformers (5.1.3.6.6.3)*
- Vacuum receiver by-pass assembly (5.1.3.6.5.2)*
- ASME coded vacuum receiver (5.1.3.6.3)*
- Lag alarm-audible alarm and indicator light (5.1.9.4.4)*
- Dry contacts for remote monitoring to master alarm
- Oxygen Assured

Optional: Motor control center with Ethernet/BMS capabilities-Consult Factory!



DUPLEX TANK MOUNTED
SCLR VACUUM PACKAGE



TRIPLEX BASE MOUNTED
SCLR VACUUM PACKAGE

NFPA 99C Compliant Medical Vacuum Systems Self-Contained Liquid Ring (SCLR)

Model	SCFM@ 19" HG Per Pump	Tank (Gal.)	HP	A	B	L	H	W	Weight (Lbs.)
SCS-3AL2041-2TAN-NFPA	6.6	120	1.5	1	1	76	72	28	875
SCS-3AL2061-2TAN-NFPA	12.1	120	3	1-1/2	1-1/2	76	72	35	950
SCS-3AL2101-2TAN-NFPA	17.6	120	4	1-1/2	1-1/2	76	72	35	950

Dimensions: Inches

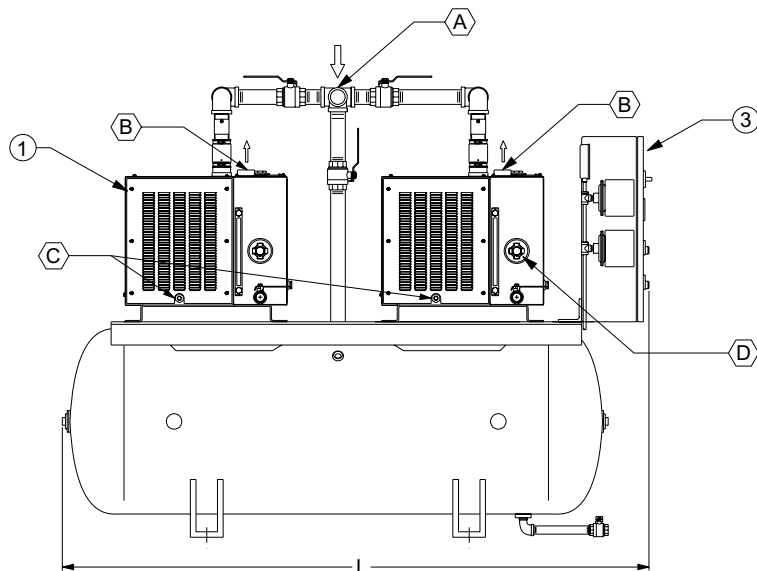

No.	Description
1	VACUUM PUMP
2	TANK
3	CONTROL PANEL
A	AIR INLET
B	AIR DISCHARGE
C	PURGE WATER CONNECTION 1/4" NPT
D	WATER OVERFLOW (1/2" OD)

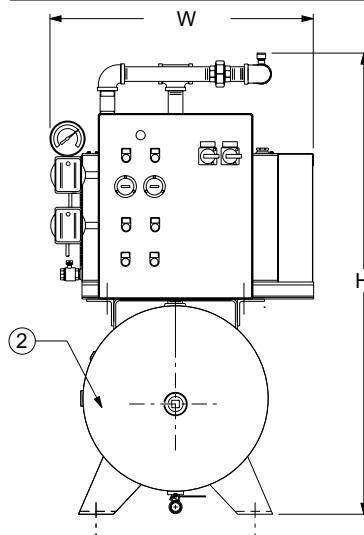

Note: Specifications are subject to change without notice. Please consult factory for specification updates.

Model	SCFM@ 19" HG Per Pump	Tank (Gal.)	HP	A	B	L	H	W	Weight (Lbs.)
SCS-3AL2101-2SAN-NFPA	17.6	120	4	1-1/2	1-1/2	80	92	60	1,650
SCS-3AL2241-2SAN-NFPA	26.5	200	5	3	2	80	92	60	2,100
SCS-3AL2251-2SAN-NFPA	31.6	200	7.5	3	2	80	92	60	2,200
SCS-3AL2281-2SAN-NFPA	53	200	10	3	2	80	92	60	2,350
SCS-3AL2341-2SAN-NFPA	69	200	15	3	2	80	92	60	2,550

Dimensions: Inches

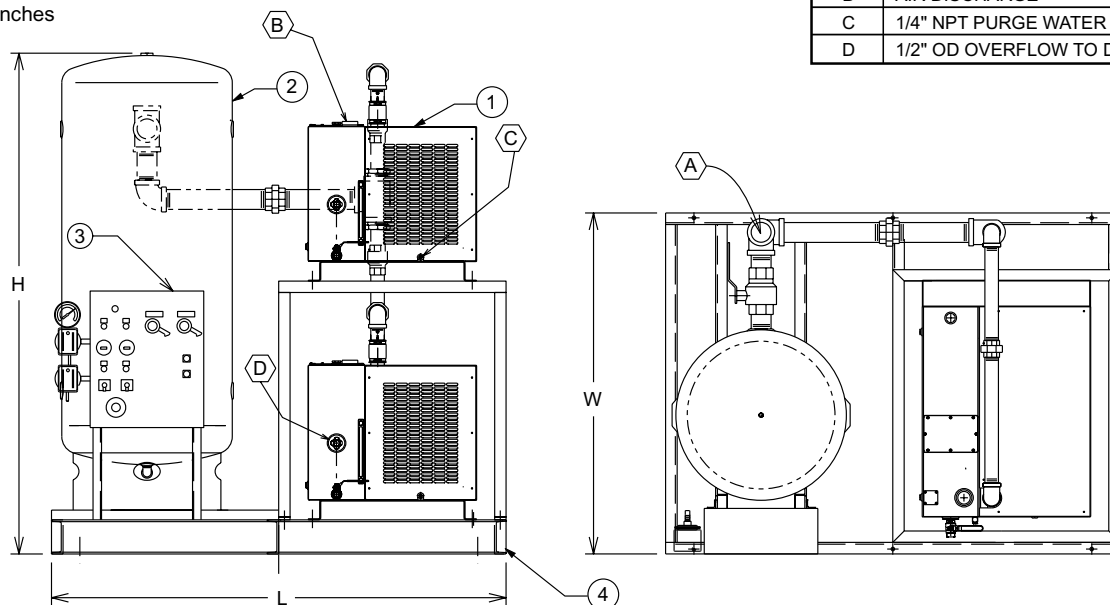

No.	Description
1	VACUUM PUMP
2	TANK
3	CONTROL PANEL
4	BASE
A	AIR INLET
B	AIR DISCHARGE
C	1/4" NPT PURGE WATER SUPPLY
D	1/2" OD OVERFLOW TO DRAIN

Note: Specifications are subject to change without notice. Please consult factory for specification updates.

AIRTECH[®]
VACUUM

150 South Van Brunt St.
Englewood, NJ 07631
Tel: 1-888-222-9940
Fax: 201-569-1696
airtech@airtechusa.com

AIRTECH[®] SOUTH
VACUUM

2211 Newmarket Parkway
Marietta, GA 30067
Tel: 770-690-0700
Fax: 770-690-0709
airtechsouth@airtechusa.com

AIRTECH[®] WEST
VACUUM

42 Digital Drive #9
Novato, CA 94949
Tel: 415-382-9000
Fax: 415-382-9700
airtechwest@airtechusa.com