

AIRTECH[®] VACUUM

Repair Instructions

3AV 30 to 3AV 430

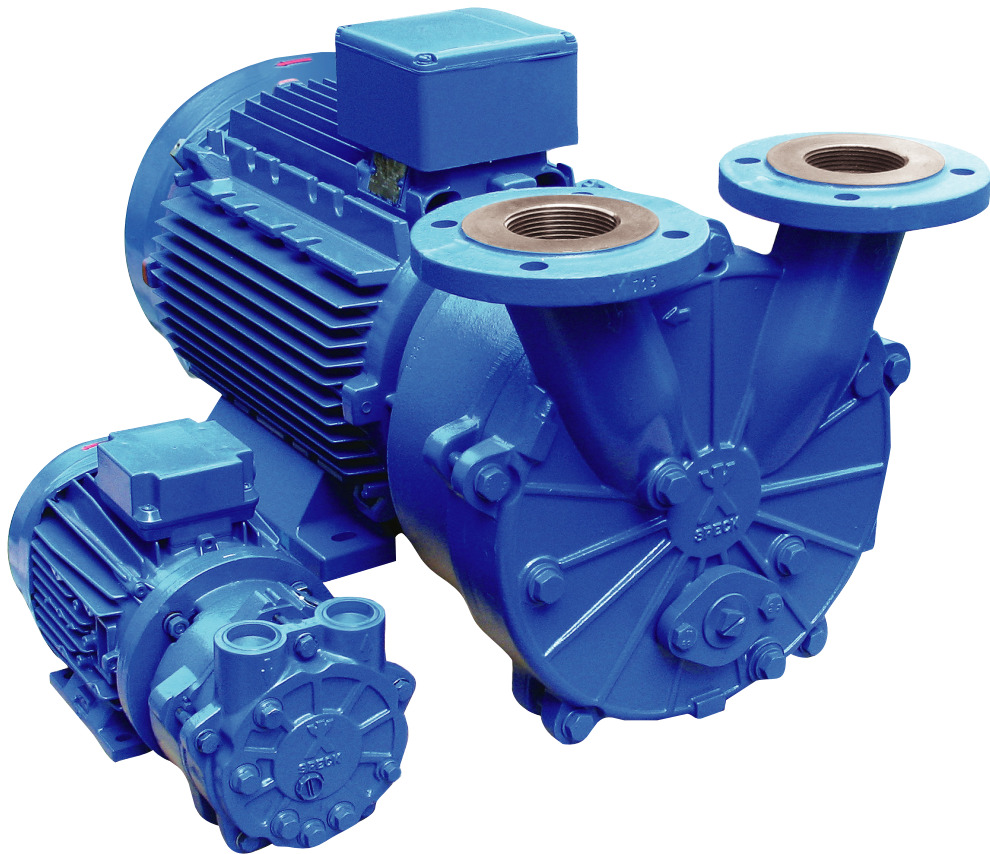

REPAIR MANUAL

3AV 30 - 3AV 430

Table of Contents

Section:	Page Number:
1.0 Dismantling Pump	3
1.1.1 3AV95/ 3AV130/ 3AV155/ 3AV330/ 3AV430	3
1.1.2 3AV255	3
1.2 Disassembling Impeller	4
1.3 Disassembling Shaft Seal Housing	4
1.4 Disassembling Mechanical Seal	4
2.0 Reassembling Pump	5
2.1 Reassembling Mechanical Seal	5
2.1.1 Rotating part of Mechanical Seal	5
2.1.2 Standstill part of Mechanical Seal	5
2.2 Reassembling Shaft Seal Housing	6
2.3 Reassembling and Adjusting Impeller	7
2.4 Reassembling Inter Casing	7
2.5 Reassembling Pump Case and Shaft Seal Housing	8
2.6 Reassembling Pump Case and Inter Casing	8

General Remarks

Before disassembly the pump, isolate the electrical input and disconnect the operation liquid connection, and inlet and outlet connections. Disassemble and reassemble the pump on a level surface. Mark all parts as they become accessible during disassembly to ensure correct positioning for reassembly. Before starting disassembly, collect the parts, materials and standard tools, which are required for disassembly and reassembly of the pump.

Special Tools, Parts and Materials

Feeler gauge

Molykote G-n Paste or equivalent

Liquid sealant e.g. Eppl 32

Metal straight edge

Loctite 242 and Primer

Solvent such as kerosene

1 Dismantling Pump

- Remove five fixed pump casing screws (901)
- Remove pump casing (101)
- Remove inter casing (137)

1.1 Disassembling Inter Casing from Pump Casing

1.1.1 Type 3AV 95/3AV 130/3AV 155/3AV 330/3AV 430

- Remove fixed hexagon socket countersunk head screw (901.2) at inter casing (137)
- Remove inter casing (137) from pump casing (101)

1.1.2 Type 3AV 255

- Remove fixed screwed plug (903) at pump casing (101)
- Remove fixed hexagon socket head cap screw (914) at pump casing (101)
- Turn around pump casing (101) and inter casing (137)
- Remove inter casing (137)

1.2 Disassembling Impeller

- Block the impeller (230) at shaft seal housing (441)
- Remove fixed hexagon nut from impeller adjusting screw
- Remove impeller (230) from shaft
- Remove impeller screw (906) and distance springs (950) from shaft. Notice position of distance springs

1.3 Disassembling Shaft Seal Housing

- Remove fixed hexagon nut or hexagon head cap screw at motor flange
- Remove shaft seal housing from motor flange

1.4 Disassembling Mechanical Seal

- Turn around shaft seal housing
- Press mechanical seal out of seat at shaft seal housing (back side)
- Remove rotating part of mechanical seal at impeller

2 Reassembling Pump

(e.g. 3AV 55)

CAUTION

Thoroughly clean all parts before reassembly, be sure to remove all old gasket material from mounting flanges. Remove burrs from mating surfaces and mounting faces. Remove rust at seat for mchanical seal.

2.1 Reassembling Mechanical Seal

2.1.1 Rotating part of Mechanical Seal

Coat the O-ring of mechanical seal with thin-bodied oil



Move mechanical seal (047) over the shaft of impeller (230). Don't touch the surface of the mechanical seal. Coat the bore of impeller with molykote

2.1.2 Standstill part of Mechanical Seal

Coat the O-ring of mechanical seal with thin-bodied oil



Install mechanical seal (047) at shaft seal housing (441). Don't touch the surface of the mechanical seal

2.2 Reassembling Shaft Seal Housing

Set motor on air ventilation cap



Install distance springs (950, with molykote coated) on the impeller adjusting screw (906). Be careful because the distance springs should be mounted as shown in the picture above. Coat the thread of impeller adjusting screw also with molykote

Tread in the impeller adjusting screw into the motor shaft



Align the studs of the motor flange with the holes of the shaft seal housing (441)

Install four washers on the studs of the motor flange

Thread on four nuts on the studs of the motor flange and tighten nuts.



2.3 Reassembling and Adjusting Impeller

Install impeller on motor shaft

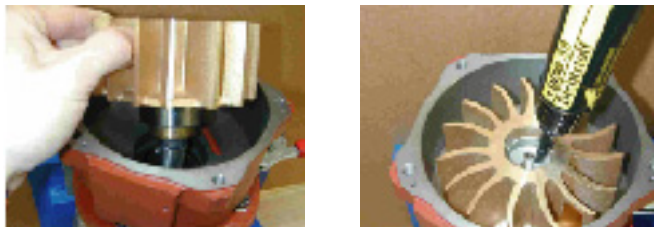

Coat the disk of impeller with liquid seal (Epple)

Install washer on the coated disk of impeller

Thread on nut to impeller adjusting screw



Adjust impeller with the impeller adjusting screw. There should be a gap of 0.1 – 0.15 mm between the surface of the impeller and the surface of the shaft seal housing. Use the metal straightedge and the feeler gauge to adjust the gap.

Block the impeller if the gap is correct. Tighten nut of the impeller screw.

Turn impeller. There should be no contact between impeller and shaft seal housing and also no contact between impeller and metal straightedge. If there is any contact re-adjust the impeller.

2.4 Reassembling Inter Casing

Coat shaft seal housing (411) with liquid seal (Epple)

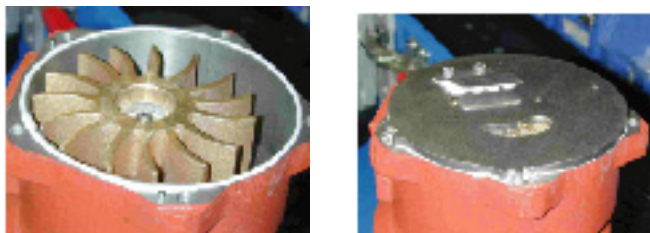

Install inter casing on shaft seal housing. Correct position of inter casing is given through the pins at shaft seal housing

2.5 Reassembling Pump Case and Shaft Seal Housing

Coat pump casing (101) with liquid seal (Epple)



Install pump case (101) on inter casing (137). Thread in five hexagon head screws (901). Tighten the screws (901) cross-wise.

Thread in all disassembled hexagon socket screwed plugs with their gaskets.

2.6 Reassembling Pump Case and Inter Casing

Type 3AV 95/3AV 130/3AV 155/3AV 330/3AV 430

Install O-Ring (412) at pump casing



Install inter casing at pump casing. Correct position is given through the pin of pump case

Apply Loctite to thread and thread in hexagon socket countersunk head screw (901.2) and tighten screw (screw 914 at 3AV 255 / screw 904 at 3AV 330-430).

2.7 Reassembling Pump Case and Shaft Seal Housing

Type 3AV 95-430

Install O-ring (412) at shaft seal housing



Install pump case (101) on shaft seal housing (441)

Thread in five hexagon head screws (901)

Tighten the screws (901) cross-wise

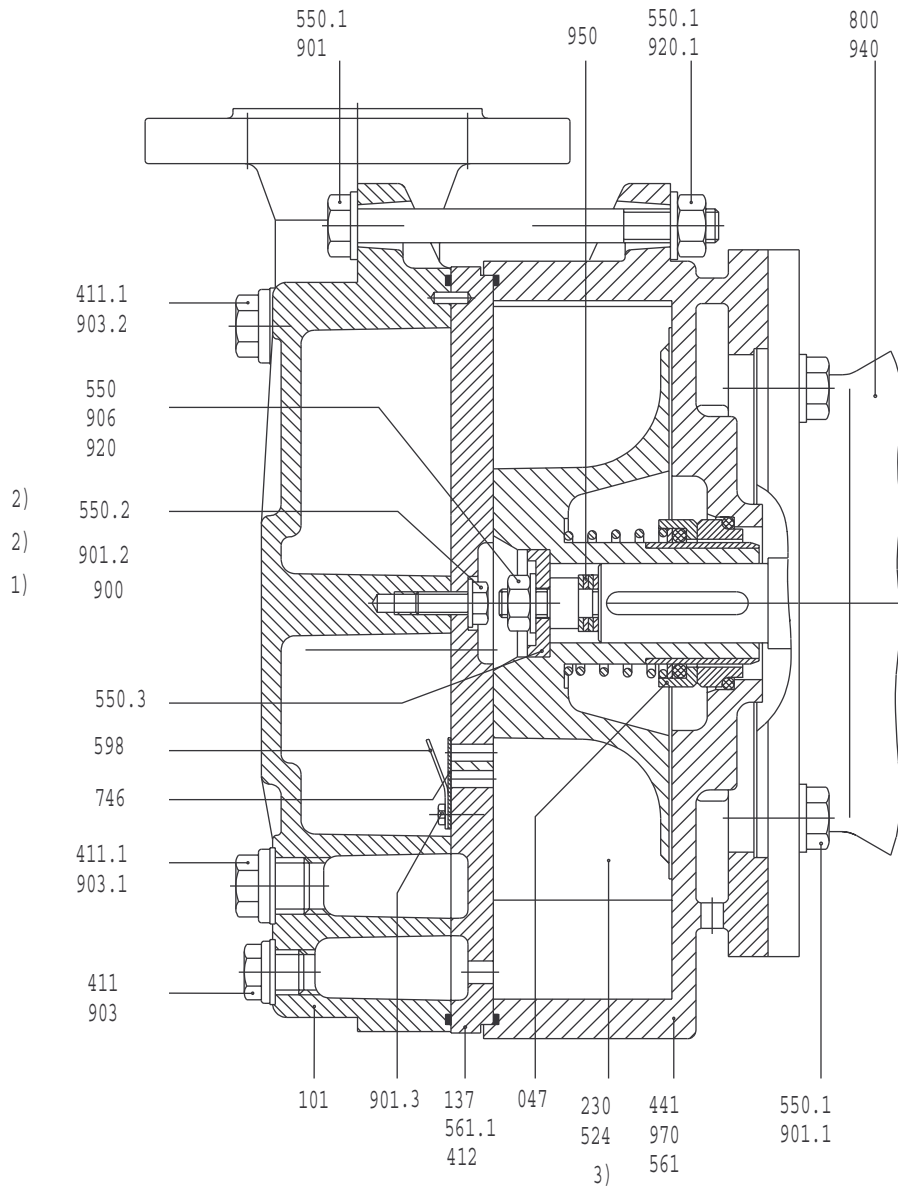

047	Gleitringdichtung	mechanical seal
101	Pumpengehäuse	pump casing
137	Steuerscheibe	inter casing
230	Laufrad	impeller
411	Dichtring	joint ring
411.1	Dichtring	joint ring
412	O-Ring	o-ring
441	Gehäuse für Wellendichtung	shaft seal housing
524	Wellenschutzhülse	shaft protection sleeve
550	Scheibe	disk
550.1	Scheibe	disk
550.2	Scheibe	disk
550.3	Scheibe	disk
561	Kerbstift	grooved pin
561.1	Kerbstift	grooved pin
598	Blech	sheet
746	Klappe	flap
800	Motor	motor
900	Schraube	screw
901	6kt Schraube	hexagon head cap screw
901.1	6kt Schraube	hexagon head cap screw
901.2	6kt Schraube	hexagon head cap screw
901.3	6kt Schraube	hexagon head cap screw
903	Verschlusschraube	screwed plug
903.1	Verschlusschraube	screwed plug
903.2	Verschlusschraube	screwed plug
906	Laufschraube	impeller screw
920	6kt Mutter	hexagon nut
920.1	6kt Mutter	hexagon nut
940	Passfeder	key
950	Feder	spring
970	Schild	shield

1) 35/55/65

2) 14/30/50/60

3) nur bei 3AV 155-14/50/55 for 3AV 155-14/50/55 only

AIRTECH[®]
VACUUM

150 South Van Brunt St.
Englewood, NJ 07631
Tel: 1-888-222-9940
Fax: 201-569-1696
airtech@airtechusa.com

AIRTECH[®] SOUTH
VACUUM

2211 Newmarket Parkway
Marietta, GA 30067
Tel: 770-690-0700
Fax: 770-690-0709
airtechsouth@airtechusa.com

AIRTECH[®] WEST
VACUUM

42 Digital Drive #9
Novato, CA 94949
Tel: 415-382-9000
Fax: 415-382-9700
airtechwest@airtechusa.com

AIRTECH[®]
CHINA

2nd Building,
Jiangbian Second Industrial Park
Songgang Town, Bao'an District
Shenzhen, China
Tel: +86-755-81730991(Ext.8018)
Fax: +86-755-81730986
www.airtechchina.com



7 / 9 Sainsbury Road
O'Connor 6163
Australia
Tel: +61 8 9331 4890
Fax: +61 8 9331 4813
www.vacuvane.com.au



Amsterdamstraße 16
D-97424 Schweinfurt,
Germany
Tel: +49 (0)9721 94563-0
Fax: +49 (0)9721 94563-29
www.vacuvane.com



c/ dels amics d'Argentona, 40
08310 Argentona (Barcelona)
Spain
Tel: (+34) 93 797 17 66
Fax: (+34) 93 797 17 54
www.hpe-technology.com