

ORION

INSTRUCTION MANUAL

OILLESS ROTARY VACUUM PUMP & BLOWER
ORION DRY PUMP

KRF15A-03
KRF25A-03
KRF40A-03



KRF40A-03



CAUTION



This product is intended only for industrial use. Use with caution.
Read this Instruction Manual and follow the instructions described herein.
Please keep this Instruction Manual for future reference.



No lubrication!

Thank you very much for your purchase of the Orion pump. Read this instruction manual in advance to use this pump safely and to ensure continuing good performance. The product mechanism and specifications are subject to change without notice. If mechanism or specifications are changed, contents of this manual may not match the actual product.

Safety Information

Read "Precautions for Safety" before operation to ensure safe operation. Safety instructions in this manual are intended to ensure safe and correct pump operation and to prevent damage or personal injury. Safety instructions in this manual are classified into  Danger,  Warning, and  Caution.



Danger

Indicates an imminently hazardous situation that, if the product is misused, may bring about death or serious injury to the operator.



Warning

Indicates a potentially hazardous situation that, if the product is misused, may bring about death or serious injury to the operator.











Caution

Indicates a critical situation that, if the product is misused, may bring about injury to the operator or damage to the product.

Additionally, the situation that is explained in  Caution column may cause serious accident. All safety information must be followed for safe operation.

- After reading this manual, keep it where an operator can refer to it anytime.
- When transferring or renting this product, attach this manual to the product where a new owner can easily refer to it for proper operation.

Symbols

	The symbol  represents warning or caution. What is shown inside or described near informs of an actual hazard. The example on the left means caution for electric shock.
	The symbol  represents prohibition. What is shown inside or described near informs of an actual action which is prohibited. The example on the left means prohibition of disassembly.
	The symbol  represents essential action or instruction. What is shown inside or described near informs of an actual instruction about operation. The example on the left means disconnect the power plug from the outlet.
	The symbol  represents important information other than warning or caution.

Although model KRF40A is used as description pictures and figures in the manual, the other models in the KRF-series are operated the same way as KRF40A if there is no note.

Be sure to read through the safety information.



Contents

Precautions for Safety.....	2
Precautions for Proper Operation.....	6
Names of Components	7
Preparation and Confirmation	9
Operation Procedure.....	16
Maintenance and Inspection	18
Troubleshooting	20
Consumable Parts.....	22
Storage (Not in Use for a Long Time)	26
Disposal	26
Specifications	27
Dimensional Outline Drawing.....	28

Precautions For Safety

Precautions for Use (Danger / Warning)



Danger

Indicates an imminently hazardous situation that, if the product is misused, may bring about death or serious injury to the operator.

	<p>Keep flammable or explosive gas out. Keep the pump from inhaling flammable or explosive gases. Do not use the unit in the place where flammable or explosive gas exists. It may cause explosion or fire.</p>
---	---

Warning

Indicates a potentially hazardous situation that, if the product is misused, may bring about death or serious injury to the operator.



	<p>Do not block the exhaust piping. (B type and V • B type) Do not operate the pump while the pressure controller is totally closed or the exhaust piping is blocked. Blocking the exhaust air may increase the pressure and temperature in exhaust piping, and result in injury and malfunction due to burst of the piping and pump parts.</p> <p>Do not wash filter element with organic solvents. When cleaning the filter element, do not use organic solvents such as thinner, alcohol, benzene, gasoline, and kerosene. It may result in explosion or fire.</p> <p>Do not remove the cover during operation. Do not operate this product while the main cover is removed. Otherwise, your hand(s) may be cut off or be seriously hurt because the cooling fan and the coupling rotate at high speeds.</p> <p>Prevent the power cord from any damage. Do not damage, bend, pull, or bind the power cord. Do not place heavy object on it or let it get caught or pinched. It may damage the cord, and may cause electric shock or fire.</p> <p>Keep this product away from water. Do not pour water over the pump and the motor, and do not use water for cleaning this product. Also, do not use this product where it may touch water or other liquid. It may cause electric shock or fire.</p>
	<p>Be alert to electric shock. Do not touch electrical parts such as power plug with wet hands. Also, do not operate switch with wet hands. It may cause electric shock.</p> <p>Never fail to put the terminal box cover on. In the case of a motor with the terminal box, do not operate it with the terminal box cover removed. It may cause electric shock.</p>
	<p>Do not modify the product. Do not modify the product. It may cause abnormal operation and may result in injury, electric shock or fire.</p>

Precautions For Safety

Precautions for Use (Warning)

Warning

Indicates a potentially hazardous situation that, if the product is misused, may bring about death or serious injury to the operator.





	<p>Be sure to ground this product. Be sure to ground the product with the screw for grounding inside the terminal box or at the lower part of the frame of the motor. Failure to do so may cause electric shock.</p>
	<p>Installation must be done by specialized personnel. The product may fall down or drop if it is improperly installed. It may result in personal injury, electric shock or fire.</p> <p>Do not operate this product under abnormal conditions. Stop the operation when it is abnormal. Then, pull out the power plug or shut off the main power supply, and consult with our dealer or a specialized company. If the operation is continued under such conditions, it may cause electric shock or fire.</p> <p>Shut off the main power supply before cleaning, maintenance and inspection. Shut off the main power supply before cleaning, maintenance, and inspection, and clearly post a sign on the power supply switch to indicate it is under cleaning, maintenance, and inspection. Failure to do so may result in electric shock or personal injury. Consult with a specialized company for maintenance and inspection.</p> <p>Inspect the power plug periodically. If the product is operated with the power plug, periodically inspect the power plug and confirm it is not covered with dust. The power plug must be fully inserted to the root of pins. If the power plug is covered with dust or not fully inserted, it may cause electric shock or fire.</p> <p>Be sure to install the protective device. Consult with a specialized company to install an earth leakage breaker. Failure to do so may cause electric shock or fire. Also, install an overload protection device (thermal relay). Operation without such a device may cause malfunction due to overload or fire.</p> <p>Contact with a specialized company when the earth leakage breaker is activated. When the earth leakage breaker is activated, contact with a specialized company. If you force to turn on the power supply, it may cause electric shock or fire.</p> <p>Do not use this product outdoors. This product is intended for indoor use. If the product is used outside and is exposed to wind or rain, the motor may suffer from incomplete insulation and may cause electric shock or fire.</p>

Precautions For Safety

Precautions for Use (Caution)

Caution

Indicates a critical situation that, if the product is misused, may bring about injury to the operator or damage to the product.

	<p>Do not use the machine over the specified pressure. If using the machine over the specified pressure, it may shorten the life of product and may cause failure, abnormal generation of heat or trouble.</p> <p>Prohibition of operation with the vacuum pipe closed (V type and V · B type) Do not operate the pump with the vacuum controller closed completely to close the vacuum pipe. Negligence may cause an abnormal pump temperature rise resulting in a product failure, protective cover deformation or burn injury.</p> <p>Do not sit on, lean on, or place objects on this product. Do not place heavy objects or object containing water on the product, and do not get on it. If you get on the product, you may fall and be injured. If water spills, it may cause rust inside or poor insulation and may cause leakage or electric shock.</p> <p>Do not operate this product with any voltage other than the rated one specified for the motor. Operation with any voltage other than the rated voltage specified for the motor may result in failure or accident.</p> <p>Prevention of melting of distribution cable covering due to contact. Install the motor so that wiring cables do not touch the motor frame. Contacting with cables may result in melting covering or fire.</p>
	<p>Be alert to burn. Do not touch areas around the dry pump, and the exhaust port and the piping surface of exhaust side. They are heated to high temperature, and it may result in burn.</p>
	<p>Inspect the earth leakage breaker periodically. Periodically check performance of the earth leakage breaker. If using the product with failure of the earth leakage breaker, it may cause electric shock in case of short circuit.</p> <p>Installation of check valve Residual pressure may reverse the rotation when the pump is stopped. Be sure to install the check valve horizontally within 50cm from the inlet port (or the exhaust port) of pump. No installation of check valve may cause malfunction.</p> <p>Turn off the main power supply in case of not using the pump for a long time. When you do not use the product for a long time, shut off the main power supply. Otherwise, it may cause electric shock or short circuit fire due to degenerated insulation.</p> <p>Be sure to wear personal protective equipment for cleaning and maintenance. When you carry out cleaning or maintenance, be sure to wear gloves. Failure to do so may result in injury or burn. When you transfer the product, be sure to wear nonslip gloves and safety shoes. Failure to do so may result in injury.</p> <p>Continuous operation is recommended. If the start and stop frequency is high, start and stop cycle in 5 minutes or less, it may cause significant lifetime deterioration or malfunction of the product.</p>
	<p>Pull out the power plug to disconnect it. When the product is used with power plug, pull the power plug to disconnect it. Pulling the power cord may result in disconnection of part of the core wire, and may cause generation of heat or deterioration.</p>

Precautions For Safety

Warning Label Position on the Product

⚠ Warning Label Position on the Product

The following warning labels are selected as most important ones out of Safety Information and are placed on the product. Read the labels before operating the product. When the labels become unreadable due to scratch or dirt, contact with your dealer to get new ones for replacement.

Electric shock



Burn



Precautions for Proper Operation

For inlet air, aim at normal temperature and normal humidity clean air with little dust but free from corrosive and explosive gases.

Normal temperature: 0 to 40 deg. C

Normal humidity: 65% +/- 20% (JIS Z 8703)

Prohibition of operation in reverse rotation.

Set the ambient temperature of the dry pump to the range of 0 to 40 degrees C.

Try not to cause condensation inside the pump.

Keep the pump away from oil, water, dust, rain, etc. **Also, never lubricate the product.**

Be sure to use under specified pressure or less.

Do not remove the main cover, and top and bottom partition plates. Removing these cover and plates may result in shortening the life of product severely due to the temperature rise.

Be sure to use the M8 bolt size for fixing the pump. Also be sure to use the plain washer (M8) and spring washer (M8) for fixing the pump. The bolt tightening torque is 10[N·m]. If the torque wrench is not used, tighten a turn and half from the hand tightening.

Be sure to install the product on the level while whole base is touching on the level surface like in following figure A. If whole base is not touching on the level surface like in following figure B, be sure to put reinforcement plates under the base to prevent the base straining.(Refer to page 28-33)

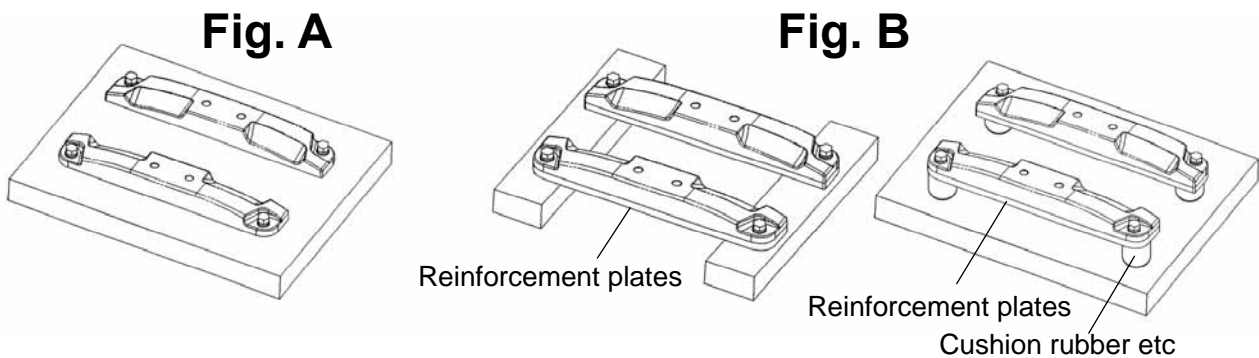

Use heat-resisting hose for exhaust pipe.

Periodically replace consumable parts (see pages 22) and replacement parts (see page 24).

Name of Components

mark indicates consumable parts that is replaced depending on wear condition when checking.
(Refer to page 22.)

mark indicates replacement parts that is replaced periodically at the specified period.
(Refer to page 24.)

mark indicates plastic parts affecting operation safety. (Refer to page 25.)

Exploded view of Dry pump (KRF15A-V-03 · 25A-V-03 · 40A-V-03)

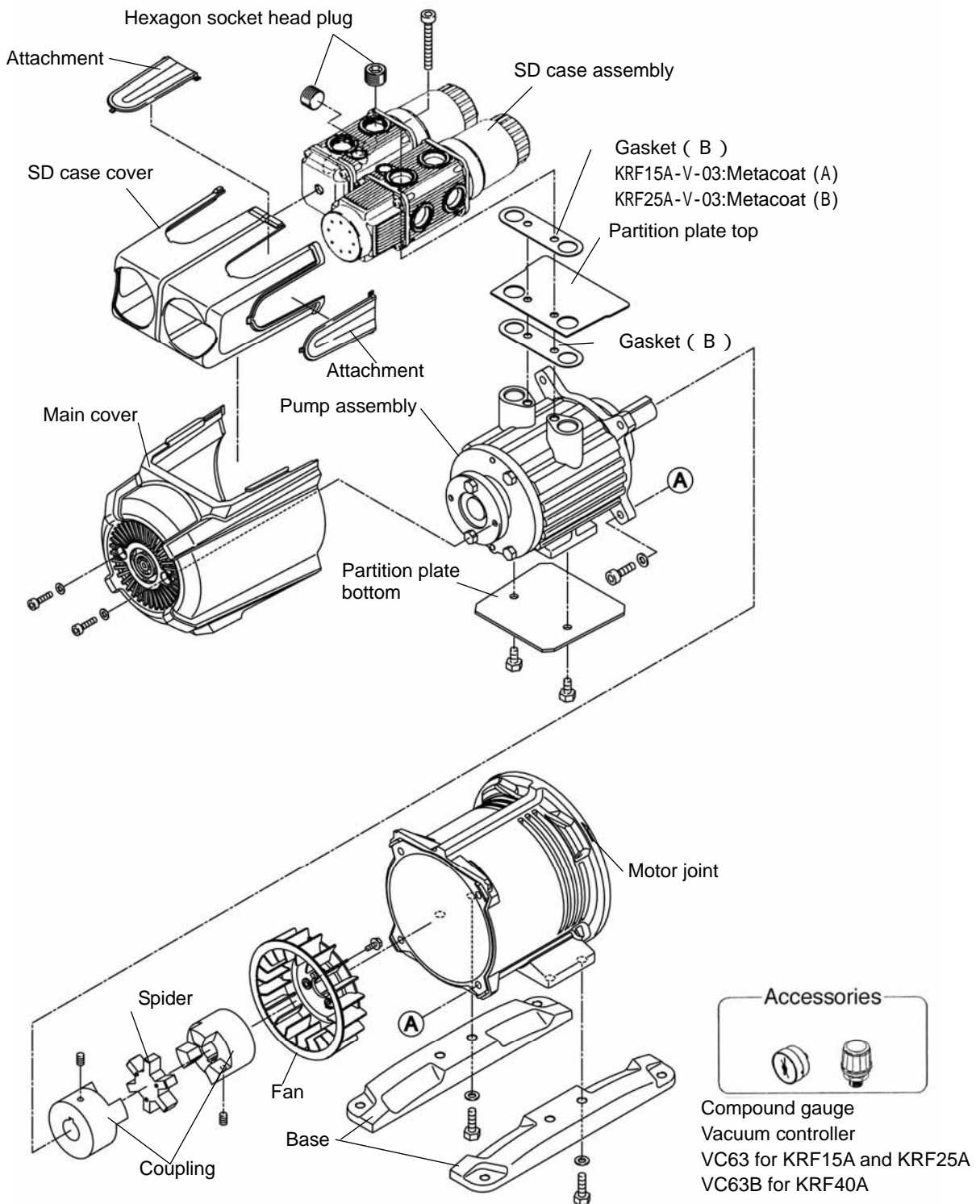

Name of Components

※● mark indicates consumable parts that is replaced depending on wear condition when checking.
(Refer to page 21 to 22.)

※△ mark indicates replacement parts that is replaced periodically at the specified period.
(Refer to page 23.)

Exploded view of SDF assembly

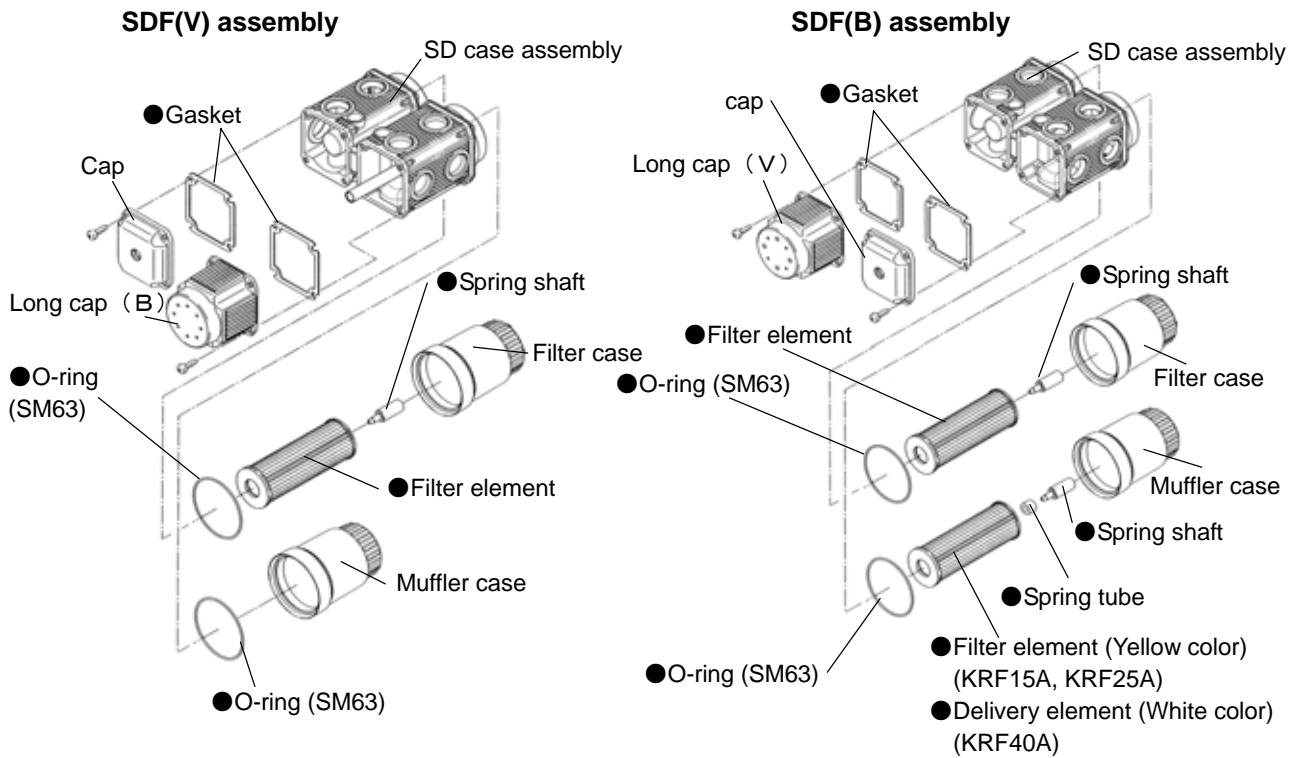

Exploded view of pump

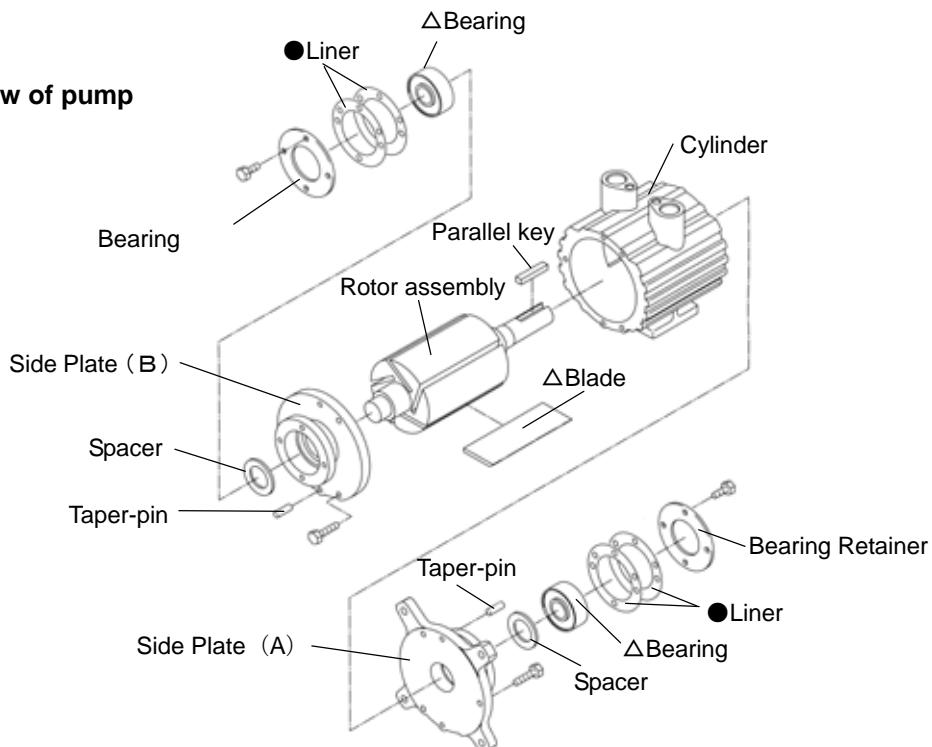

Preparation and Confirmation

Motor Installation procedure

Motor Installation procedure

This pump has no motor. So, you need to install the motor. Please make a selection of the motor with reference to the specification list (P27).

Install the motor to refer to the following procedures. If you install the motor improper, it may be at fault or generate noise.

Caution : Install the motor to refer to the following procedures. If you install the motor improper, it may be at fault or generate noise.

Installing the motor

[For KRF15A-03 & KRF40A-03 models]

1. Make sure the motor shaft and the fan coupling assembly hole (which accepts the motor shaft) is free from dust and any scratches.
2. Make sure the fan coupling assembly connects the motor via the coupling on the pump side of the unit within the motor joint.

Insert the motor shaft into the fan coupling assembly hole.

Insert until the face of the motor flange contacts the face of the motor joint flange.

When inserting the motor shaft, make sure the shaft goes into the hole in the center of the fan coupling.

In case the shaft does not go into the fan coupling hole easily, don't force it. Remove the motor from the fan coupling and inspect the shaft and coupling for signs of dirt or scratches. In case of scratches,

clean surfaces with an oil stone or sandpaper (about 240 grit.)

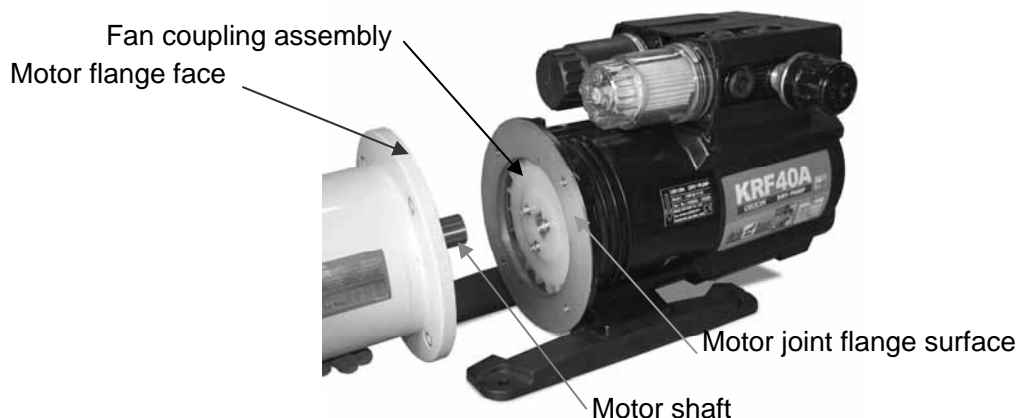

3. After fully inserting the motor shaft into the fan coupling assembly hole, fix the motor to the motor joint using the provided bolts.

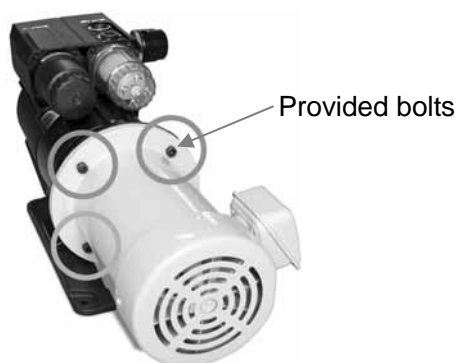

Preparation and Confirmation

Motor Installation procedure

4. Fix the fan coupling assembly to the motor shaft by tightening the fan coupling set screw. The screw is tightened with a hex key via the hole at the top of the motor joint.
Torque the set screw. Tighten the socket cap set screw to a torque of 15.7 N-m (139 in-lb).
When tightening, ensure the teeth of the fan coupling assemble are properly fit into the rubber "spider" and that the fan coupling assembly does not slip toward the motor.
Use a socket wrench adapted to a hex key or similar tool to tighten the set screw since a plain hex key might twist or not yield enough force to ensure sufficient tightening.



5. After tightening the set screw on the fan coupling assembly, make sure the fan rotates smoothly by turning the fan blades with a screwdriver or other narrow tool.



Preparation and Confirmation

Motor Installation procedure

[For KRF25A-03 models]

1. Make sure the motor shaft and the fan coupling assembly hole (which accepts the motor shaft) is free from dust and any scratches.

2. Remove the fan coupling assembly from the motor joint.

Insert the fan coupling assembly onto the motor shaft. Position the end of the motor shaft so it is flush with the end of the fan coupling assembly and tighten the set screw to fix the motor shaft to the fan coupling assembly.

Torque the set screw. For the new model with the socket cap set screw, torque to 15.7 N-m (139 in-lb). For the old model with the standard set screw, torque to 17.7 N-m (157 in-lb).

In case the motor shaft cannot be smoothly inserted into the fan coupling assembly, do not force it. Remove the fan coupling assembly from the motor shaft and inspect the shaft and coupling for signs of dirt or scratches. In case of scratches, clean the surfaces with an oil stone or sandpaper (about 240 grit.)

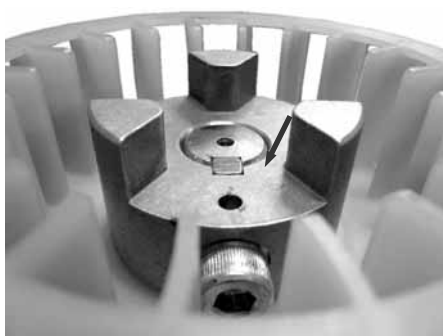

3. Fix the motor to the motor joint using the provided bolts.

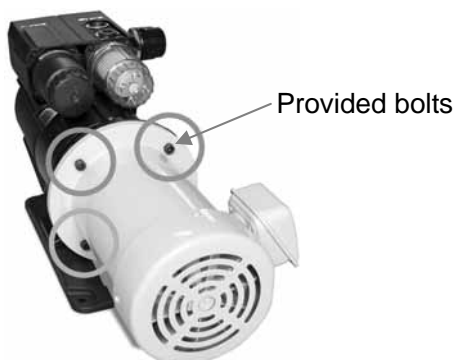

4. Make sure the fan rotates smoothly by turning the fan blades with a screwdriver or other narrow tool.

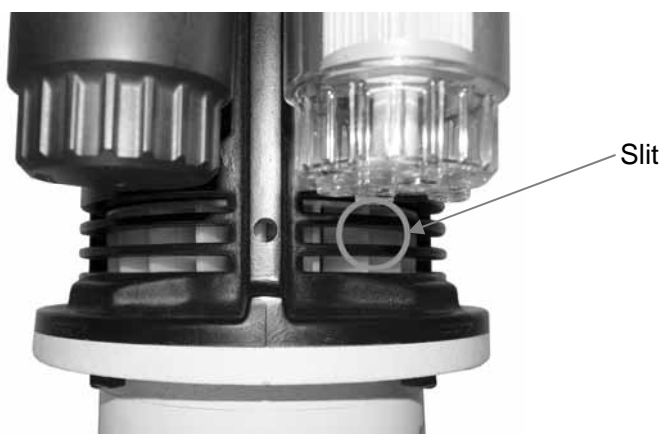

Preparation and Confirmation

Before Installation/ Installation

Danger

Do not use the product where flammable gas or explosive gas may exist.

Warning

Set up the product where it is protected from water, oil and dust.

Please use the product indoors.

Do not set up the product where corrosive gas (chlorine or sulfur dioxide gas) exists.

Do not set up the product under direct sunlight.

Use the product where the ambient temperature ranges 0 to 40 degrees in Celsius.

When the product weighs 25kg or over, **hold the product with two persons for transfer.**

Before Installation

IMPORTANT

The product is heavy. Be careful enough when moving the product.

Upon receiving the product, check it carefully for signs of shipping-related damage like scratches, deformation, etc. If you notice a problem, contact with your dealer.

Be sure to check the name plate whether purchased product is right model as you ordered.

When the product is delivered with accessories, be sure to check the accessories whether there are all the parts or not.



Name plate

Installation

IMPORTANT

When the product is 25kg or over, **hold the product with two persons.**

Also, **do not hold the terminal box of motor, filter case, and controller** when holding with two persons. **Holding the terminal box and filter case of the motor may result in injury, damage or malfunction if product or parts of it are dropped.**

In case of using a hanging belt, be sure to belt as shown in the photo.

Do not hold these parts.



Photo



Preparation and Confirmation

Installation Site/ Gauge & Controller

Installation Site

Warning

Installation should be carried out by your dealer or special service company. Improper installation may result in vibration, electric shock, or fire.

Set up the product in a wide space where you can easily maintain, inspect and overhaul the product. Ambient temperature of the pump is 40 deg. C or less. If there is any heat source near the pump, be sure to check the ambient temperature does not exceed 40 deg. C.

Using the product in the enclosed space may result in malfunction due to the generation of heat of the pump. Ventilate adequately around the pump, and be careful not to exceed the permissible ambient temperature.

Be sure to install the product horizontally while the whole base plate is touching the level surface.

Warning

Installation of check valve

Residual pressure may reverse rotation when the pump is stopped. Be sure to install the check valve within 50cm from the inlet port of the pump. No installation of check valve may cause malfunction.

Gauge & controller

Be sure to install the gauge according to following procedure.

1 Remove the cover.

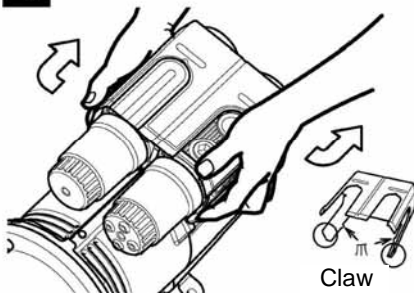

2 Install the gauge.

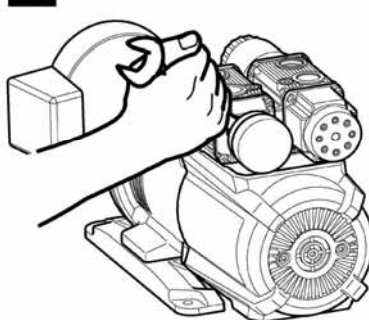

3 Press it back in place until the cover claw is locked.



Spread the figure part, unlock the claw and pull forward.

For the controller installation position, refer to the outer dimension drawing provided on P28-33.

Do not apply a sealing tape when installing the pressure gauge. (Do not overtighten.)

Do not apply a sealing tape on the threads. After tightening the controller hand-tight, give an additional quarter to half turn using a tool. Smooth surface due to application of a sealing tape may result in excessively tightening the controller. This may damage or deform the thread part and cause malfunction. (There is no need of securing high airtightness using a sealing tape or adhesive agent because the pump is designed for low pressure/vacuum.)

Compound gauge is a part that is weak against impacts. Do not hit or drop the product with compound gauge.

Preparation and Confirmation

Piping

Piping

1. Avoid direct connection with steel pipe.

- Use hose for inlet and exhaust piping. In case of direct connection with steel pipe, resonance with the piping system **may cause noise or vibration**. For exhaust piping, use heat resistant and pressure resistant (100kPa or over) hose.
- Completely remove dirt and dust inside the hose before piping.

2. When intake air contains a big amount of dust, or if dust grains are very fine (10 μ m or less), use an appropriate filter in addition to the accessory filter.

3. Install the hose of the exhaust piping system properly in order to prevent condensed water inside the system from entering the pump, and from discharging from the piping end.

If condensed water in the piping system enters the pump, the pump inside may be locked by rust or the blades may not come out. To avoid this situation, take the following measures:

Install the valve or drain in the exhaust piping system so that the condensation of water occurred inside the system can drain out. Also, drain out the collected condensation of water periodically. (See Figure 1.)

- Provide valve or drain hose on the pump side in order to prevent condensed water from entering into the pump.
- In case of a long piping system, provide valve or drain hose in the halfway of the system.
- When condensed water discharges from the piping end, install a valve or drain hose at the piping end.

If the pump is not frequently used, idle the pump for 10 to 15 minutes after finishing operation.

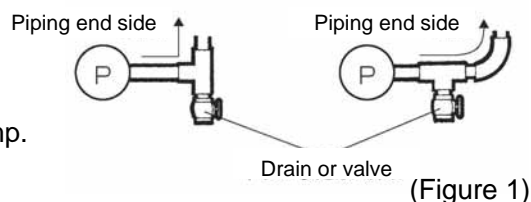

(Figure 1)

4. If reverse rotation is caused by residual pressure upon stopping the pump, blade damage is likely to be incurred. Please install a check valve within 50 cm from the pump's inlet port (or exhaust port) to prevent this from happening. In installing a check valve, install it levelly to the floor. Negligence may cause pulsation or abnormal noises. (Figure 2)

(Recommended check valve: manufacturer's product name: JIS compliant KITZ bronze swing check valve)

5. Do not apply a sealing tape when connecting pipes. Pieces of torn sealing tape may cause controller malfunction or abnormal operation sound.

6. Do not overtighten pipes. Overtightening pipes may damage the SD case.

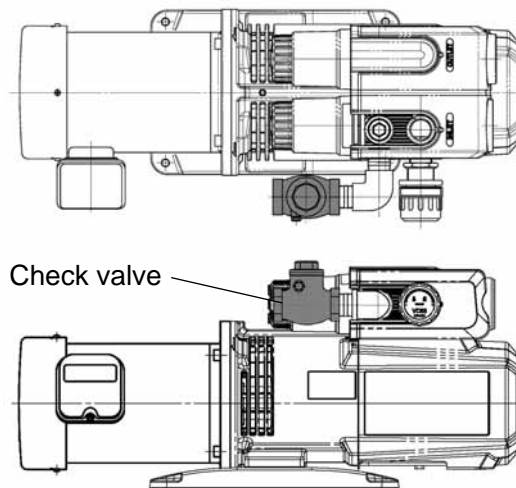

(Figure 2) Example of check valve installation

Preparation and Confirmation

Electrical Wiring

Electrical Wiring



Warning

Contact with a specialized company to install an earth leakage breaker. **Failure to do so may cause electric shock or fire.** Also, install an overload protection device (thermal relay). **Failure to do so may cause failure to the product due to overload or fire.**

1. Install the earth leakage breaker according to the electrical regulations.

Set the breaking capacity to 1.5 times the current value shown on the motor name plate as a rough guiding value. Select a sensed current of 30mA.

Consult with a specialized company for electrical installation.

2. Be sure to install the grounding.

- Location of grounding screws:

The grounding is attached on the terminal box.

(You can find the mark "E" or mark "⏚" near the screw.)

- Select a copper wire, with a nominal cross section bigger than the cross section shown in the example, as grounding wire.

Motor rated output (kW)	Nominal cross section (mm ²)
2.2 or less	2

- When the grounding screw becomes loose due to vibration during operation, sparks will occur at the grounding section. Wire the grounding cable so that the grounding screw does not loose due to vibration during operation, and tighten the screw with locking.

3. Install the overload protection device (e.g. thermal relay). Make the V specification 100%, and B and VB specifications 110% against the rated current value written on the motor name plate for the set value.

4. Operate the pump with the rated power supply written on the motor name plate.

5. In case of single-phase specification, when the lead wire is connected, be sure to protect the connection part with insulating tape, etc.

6. Select a power cord referring to the current value shown on the pump name plate.

7. Be sure to keep the power supply cable with holding assembly in order not to get stressed to the internal power supply connection terminal at the time of pulling the cable.

(Recommended holding assembly: Maker; UI Lapp GMBH/ Product name: Skintop/ Model: ST-M, STR-M)

Operation Procedure

Check before Operation/ Operation

Check before Operation

Install the earth leakage breaker according to electrical regulations.

Consult with a specialized company for electrical installation.

Install the overload protection device (e.g. thermal relay). Make the V specification 100%, and B and VB specifications 110% against the rated current value written on the motor name plate for the set value.

Before using a machine that has not been used for a long period of time, be sure to check that the power is off, and then rotate the rotor (fan, motor fan etc.) gently to confirm that it can be rotated smoothly.

Compound gauge is a part that is weak against impacts. Do not hit or drop a product with compound gauge.

When storage temperature and operation temperature are differing more than 10 degrees in Celsius, leave the pump at the operation site for more than 2 hours in order to eliminate the temperature difference before using.

If condensation water occurred, and the condensation water enters into the pump, it may result in rust, lock, and vanes might block.

Operation

1. Be sure to check by inching that the rotating direction is the same as the one shown on the "rotating direction arrow" when it is viewed from the motor fan side.
2. Turn on the power switch.
3. Use the controller to adjust vacuum level and exhaust pressure.



「Rotating direction arrow」



Check: Be sure to check the rotating direction.

Adjustment of vacuum level and exhaust pressure

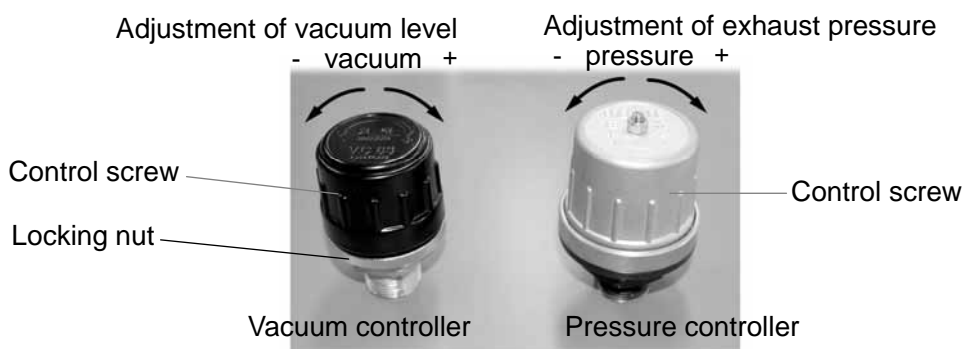

Adjustment of vacuum level (Vacuum controller)

1. Turn the locking nut clockwise to unlock the control screw.
2. Turn the control screw until the desired vacuum level is obtained on the gauge.
3. Turn the locking nut counterclockwise to lock the control screw.

Adjustment of exhaust pressure (Pressure controller)

1. Turn the control screw until the desired exhaust pressure is obtained on the gauge.

Operation Procedure

Pressure range during operation/ Stop

Pressure range during operation

	kPa		KRF15A-03	KRF25A-03	KRF40A-03
Use as vacuum pump (V type)	Continuous operative vacuum	Recommended range (1)	60 or lower		
		Maximum value (2)	75	80	
Use as blower pump(B type)	Continuous exhaust pressure	Recommended range (1)	60 or lower		
		Maximum value (2)	70		
Use as vacuum pump and blower pump (V, B type)	Continuous operative pressure	Recommended range (1)	Total of continuous operative vacuum and continuous exhaust pressure: 60kPa or lower		
		Maximum value (2)	Total of continuous operative vacuum and continuous exhaust pressure: 75kPa	Total of continuous operative vacuum and continuous exhaust pressure: 80kPa	

1 Recommended range: The pump can exert its optimal performance (life, operation noise, etc.) under vacuum/pressure within this range.

Use the pump within the recommended range unless the higher vacuum/pressure is required.

2 Maximum value: This is the upper vacuum/pressure limit for continuous operation of the pump.

Avoid operating the pump over the upper limit. Operation beyond this limit will shorten the working life and also may cause failure or accident.

Contact with Orion or Orion dealer for other usage.

Stop

Shut off the power switch.

Maintenance and Inspection

Cleaning of filter element



Warning

Turn off the main power supply before cleaning, maintenance and inspection.

Turn off the main power supply before cleaning, maintenance and inspection, and clearly post a sign on the power supply switch to indicate it is under maintenance. **Failure to do so may result in electric shock or personal injury.**

Consult with a specialized company for maintenance and inspection.

Do not wash filter element with organic solvents.

When cleaning the filter element, **do not use organic solvents such as thinner, alcohol, benzene, gasoline, and kerosene.** It may result in explosion or fire.



Caution

Be sure to wear protective wear.

When you carry out cleaning or maintenance, be sure to wear gloves. **Failure to do so may result in injury or burn.**

When you transfer the product, be sure to wear nonslip gloves and safety shoes. **Failure to do so may result in injury.**

Maintenance

Cleaning of Filter Element

1. Cleaning of Filter Element and Delivery element

When debris deposits on the filter element, remove the filter case and muffler case, and then remove the filter element and the delivery element to get rid of the debris with an air blow. If a fouled filter element cannot be cleaned with air blows, replace it with a new one.

※● indicates the consumable parts (parts to be replaced depending on wear condition when checking.) .Refer to P22 to 23.

※Put O rings on the roots of the male screws of the case attachment seats and take care not to smash them with threads when you screw in the filter case and the muffler case.

※Screw in the filter case and the muffler case until they come to close contact with the case attachment seats.

※Pay attention to the correct direction of attachment for the filter element. If installed in the wrong direction, a product failure may result.

※Take care not to install the filter case (clear) and the muffler case (black) crosswise. If installed crosswise, filter case breakage may result and cause personal injury.

Inspection period	Contents
Once a week	Remove dust or dirt

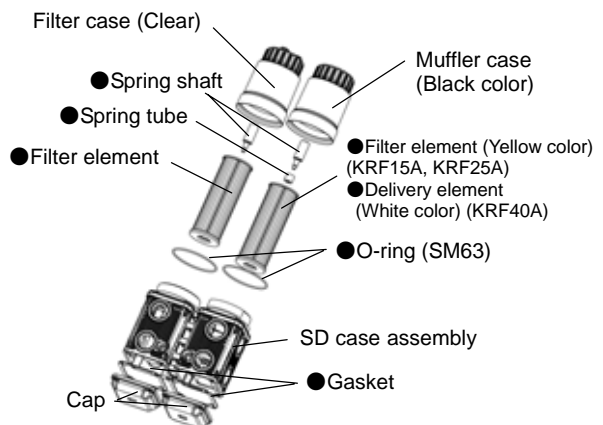

2. Cleaning of Controller

(Vacuum controller, Pressure controller)

If the sheet surface of the controller is very dirty, the function may deteriorate. Disassemble the controller periodically, and remove the dirt of each part.

Inspection period	Contents
Once a month	Disassembly cleaning

3. Inspection of Piping

Be sure to check that there is air leakage, clogging, or loosening part on the piping.

Inspection period	Contents
Once a month	Air leak, clogging, looseness of tightened parts

(Vacuum controller)

VC63 for KRF15A-03 and KRF25A-03
VC63B for KRF40A-03

(Pressure controller)

PCA6

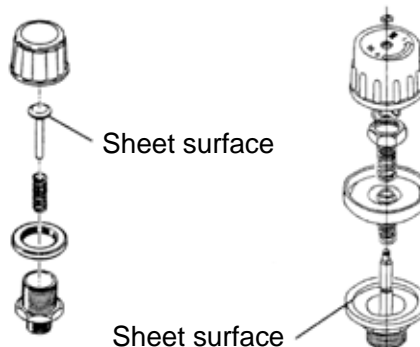

Troubleshooting



Warning

Turn off the main power supply before cleaning, maintenance and inspection.

Turn off the main power supply before cleaning, maintenance and inspection, and clearly post a sign on the power supply switch to indicate it is under maintenance. **Failure to do so may result in electric shock or personal injury.**

Consult with a specialized company for maintenance and inspection.



Caution

Be sure to wear protective wear.

When you carry out cleaning or maintenance, be sure to wear gloves. **Failure to do so may result in injury or burn.**

When you transfer the product, be sure to wear non-slip gloves and safety shoes. **Failure to do so may result in injury.**



Check abnormal factors.

Troubleshooting

Condition	Cause	Corrective action
Vacuum level does not increase.	Filter element is clogged with dust, and air cannot be taken in.	Remove the element and blow off dust from the element with compressed air. If the element becomes dirty, replace it with a new one.
	Oil entered into the pump, and the vane cannot come out.	Consult with our dealer or service personnel.
	Foreign object entered into the pump and the vane cannot come out.	
	Due to rust inside of the pump by intaking water, the vane cannot come out.	
	Due to condensation inside of the pump, the vane cannot come out.	
	Damage to meter	Replace the meter.
	Tightening of filter case, piping, air tank are not tightened well, and air leaks.	Consult with our dealer or service personnel.
	The coupling fixing bolt is loose.	
	Decreased pump rotating speed due to motor malfunction.	
	Damaged vane.	
Worn vane.		
When an abnormal noise is heard or when the meter shows pulsations.	An abnormal noise is occurred because the pressure is out of allowable range.	Return the pressure to the applicable pressure range.
	Excessive exhaust pressure causes an abnormal noise.	Adjust the exhaust resistance to return the exhaust pressure to normal.
	The abnormal noise occurs due to misfitting of the coupling.	Consult with our dealer or service personnel.
	The abnormal noise occurs due to burning of the motor.	
	The abnormal noise occurs because mounting bolts became loose.	
	Damage to meter.	Replace the meter.
	Filter element is clogged with dust, and air cannot be taken in.	Remove the element and blow off dust from the element with compressed air. If the element becomes dirty, replace it with a new one.
	Oil entered into the pump, and the vanes cannot come out.	Consult with our dealer or service personnel.
	Due to condensation inside of the pump, the vanes cannot come out.	
	The vanes were broken because foreign object(s) entered into the pump.	
The vanes were broken because foreign object(s) entered into the pump.		
When pump is stopped.	The rotor was touched because the pressure was out of applicable pressure range.	Consult with our dealer or service personnel.
	Defective electromechanical system	

Consumable parts

List of Consumable Parts

List of Consumable Parts (Parts to be replaced depending on wear condition when checking.)

Name of Parts	Model	KRF15A-03	KRF25A-03	KRF40A-03
Filter element (Inlet side)	Parts Number	04000028010		04009779010
	Quantity /unit	1		
	Inspection period	Every week		
	Replacement criterion	When it was damaged, or when dirt cannot be removed by blowing air.		
Filter element (exhaust side) ※2	Parts Number	04000028010		_____
	Quantity /unit	1		
	Inspection period	Every week		
	Replacement criterion	When it was damaged, or when dirt cannot be removed by blowing air.		
Delivery element (exhaust side) ※3	Parts Number	_____	_____	04044334010
	Quantity /unit	1		
	Inspection period	Every week		
	Replacement criterion	When it was damaged, or when dirt cannot be removed by blowing air.		
Metacoat (A) ※4	Parts Number	03037233010	_____	_____
	Quantity /unit	1	_____	_____
	Inspection period	At the time of removal of SD case	_____	_____
	Replacement criterion	When it was damaged or crushed.	_____	_____
Metacoat (B) ※5	Parts Number	_____	03037234010	_____
	Quantity /unit	_____	1	_____
	Inspection period	_____	At the time of removal of SD case	_____
	Replacement criterion	_____	When it was damaged or crushed.	_____
Gasket (B)	Parts Number	04009579010		_____
	Quantity /unit	※6		2
	Inspection period	At the time of removal of SD case		
	Replacement criterion	When it was damaged or crushed.		
Washer	Parts Number	33000300020		
	Quantity /unit	2		
	Inspection period	At the time of removal of SD case		
	Replacement criterion	When it was damaged or crushed.		
O-ring	Parts Number	35152100050		
	Quantity /unit	2		
	Inspection period	At the time of check and replacement of element		
	Replacement criterion	When it was damaged or crushed.		
Gasket	Parts Number	04100818010		
	Quantity /unit	2		
	Inspection period	At the time of removal of cap		
	Replacement criterion	When it was damaged or crushed.		
Liner ※1	Parts Number	040000370□0	040000380□0	040000400□0
	Quantity /unit	To be decided by actual positioning.		
	Inspection period	At the time of replacement of vane.		
	Replacement criterion	When it was damaged.		
Spring shaft	Parts Number	04100817010		
	Quantity /unit	※7		
	Inspection period	At the time of check and replacement of element		
	Replacement criterion	When it was damaged or crushed.		
Spring tube	Parts Number	04039359010		
	Quantity /unit	※8		
	Inspection period	At the time of check and replacement of element		
	Replacement criterion	When it was damaged or crushed.		
Spider	Parts Number	04044059010	04044087010	04100620010
	Quantity /unit	1		
	Inspection period	Six months		
	Replacement criterion	When it was damaged or crushed.		

Consumable parts

List of Consumable Parts /List of Motor Maintenance Cycle

- ※1 Parts number of second digits from the right side differs depending on thickness.
0.2t (white) becomes 1, 0.1t (black) becomes 2, 0.05t (yellow) becomes 3, 0.03t (red) becomes 4.
- ※2 Only used for KRF15A, KRF25A blowers, and vacuum & blower models.
(KRFA15-B-03) (KRF15A-VB-03) (KRF25A-B-03) (KRF25A-VB-03)
- ※3 Only used for KRF40A blower, and vacuum & blower models.
(KRF40A-B-03 and KRF40A-VB-03)
- ※4,5 Used for vacuum, and vacuum & blower models.
(KRF15A-V-03) (KRF15A-VB-03) (KRF25A-V-03) (KRF25A-VB-03)
- ※6 (1) 2 pcs for blower models.
(KRF15A-B-03) (KRF25A-B-03)
(2) 1 pc for vacuum, and vacuum & blower models.
(KRF15A-V-03) (KRF15A-VB-03) (KRF25A-V-03) (KRF25A-VB-03)
- ※7 (1) 1 pc for vacuum models.
(KRF15A-V-03, KRF25A-V-03, and KRF40A-V-03)
(2) 2 pcs for blower, and vacuum & blower models.
(KRF15A-B-03) (KRF15A-VB-03) (KRF25A-B-03) (KRF25A-VB-03)
(KRF40A-B-03 and KRF40A-VB-03)
- ※8 Blower, and vacuum & blower models.
(KRFA15-B-03) (KRF15A-VB-03) (KRF25A-B-03) (KRF25A-VB-03)
(KRF40A-B-03 and KRF40A-VB-03)

Consumable parts

List of Replacement Parts

List of Replacement Parts (Parts to be replaced periodically at specified period.)

Name of parts	Model			KRF15A-03	KRF25A-03	KRF40A-03
Vane	Parts Number			04101754010	04100888010	04100889010
	Quantity /unit			4	4	5
	Replace-ment time	Continuous operative vacuum and Continuous exhaust pressure	Recommen ded range (1)	10,000	10,000	8,500
			Maximum value (2)	7,500	7,500	6,500
Bearing	Parts Number			0A000227000	0A000228000	0A000229000
	Quantity /unit			2	2	2
	Replace-ment time	Continuous operative vacuum and Continuous exhaust pressure	Recommen ded range (1)	10,000	10,000	8,500
			Maximum value (2)	7,500	7,500	6,500

1 Recommended range: The pump can exert its optimal performance (life, operation noise, etc.) under vacuum/pressure within this range.

Use the pump within the recommended range unless the higher vacuum/pressure is required.

2 Maximum value: This is the upper vacuum/pressure limit for continuous operation of the pump.

Avoid operating the pump over the upper limit. Operation beyond this limit will shorten the working life and also may cause failure or accident.

The indicated blade replacement period is recommended in order to help prevent breakdown due to blade wear, and assumes average blade wear at 60Hz operation; specific performance is not guaranteed. The blade should be replaced soon if performance decreases or noise levels increase.

Consider the replacement time as a guide, and carry out the periodic replacement.

Advanced technologies are required to replace vanes and bearings, so contact with our dealer or service personnel.

Use the maintenance kit for replacement parts.

Name of Parts		Unit	Maintenance kit Assembly 15	Maintenance kit Assembly 25	Maintenance kit Assembly 40
Model			KRF15A-03	KRF25A-03	KRF40A-03
Parts no.			04100311010	04100312010	04100313010
Items	Vane	Pcs/Unit	4		5
	Bearing		2		
	Liner (white)		4		
	Liner (black)		4		
	Liner (yellow)		6		
	Liner (red)		8		

Consumable parts

Maintenance of plastic parts affecting operation safety

Maintenance of plastic parts affecting operation safety

Caution

Replace the following plastic parts affecting operation safety promptly upon detection of breakage or deformation. Failure to do so may cause personal injury.

Name of Parts	Model	KRF15A	KRF25A	KRF40A
Main cover assembly	Parts Number	03103233020	03103234020	03103235020
	Quantity /unit	1		

※  mark affixed to the designations means that they are plastic parts affecting operation safety.

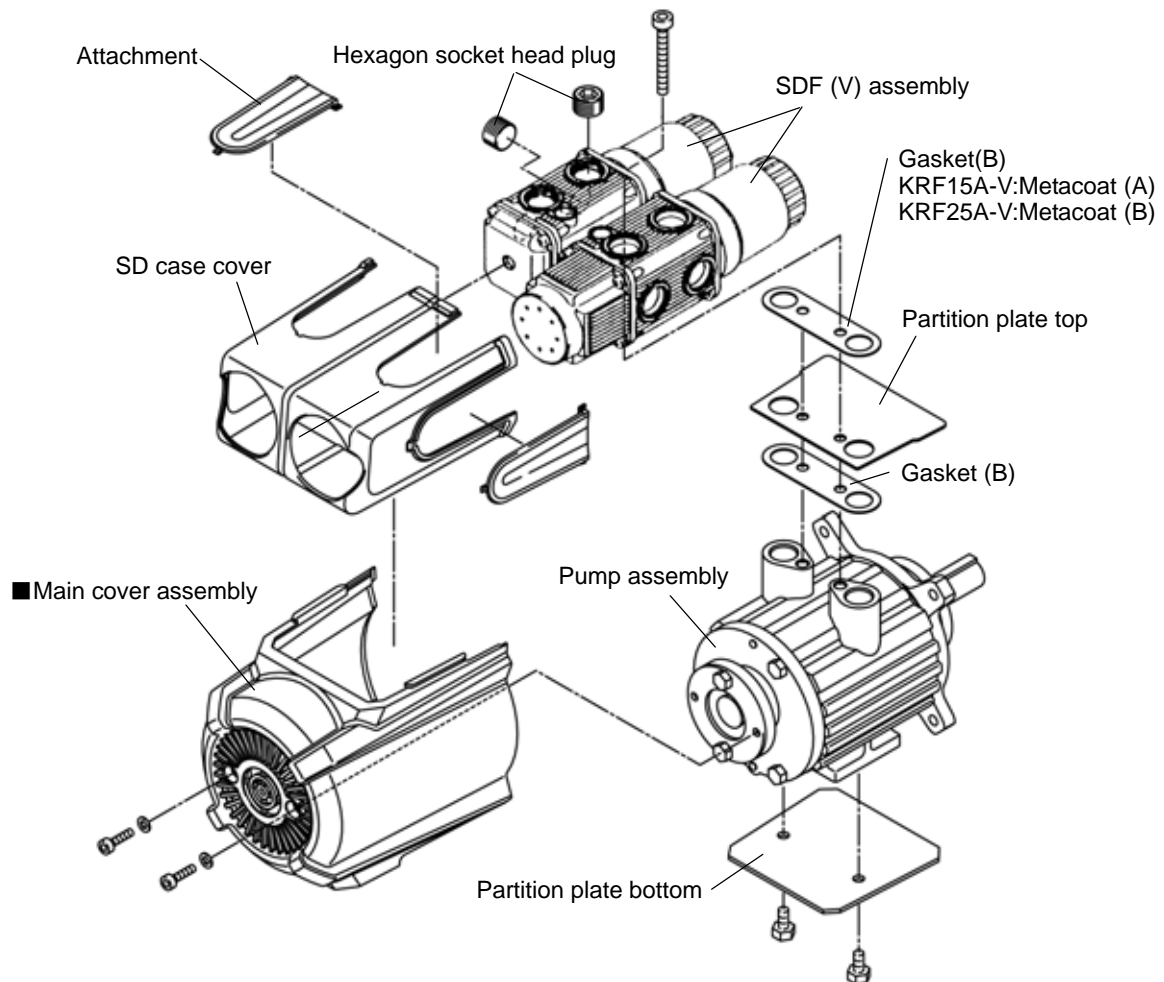

Storage (Not in Use for a Long Time)

Storing method/ Storage location

Storing method

Pay attention to formation of rust if the pump is not used immediately after received or if the regularly used pump has not been used for a long time.

Storage location

1. Store the product indoors and place the cover on the pump to protect it from water and dust.
2. Store the product where it is protected from water, oil and dust.
3. Store the product in a dry and clean place.
4. Store the product in an airy place where the ambient temperature is 40 degrees in Celsius or less.
5. Do not store the product where toxic gas such as chlorine gas or sulfur dioxide gas, which corrodes the pump, is generated.
6. Store the product in a low humidity place to prevent the pump from rusting.

Disposal

Be sure to entrust the disposal of the Product to the specialists in the trade of disposal of industrial wastes, observing Law about Disposal of Wastes and the Cleaning.

Specifications

Specification list

Specification list

Model 1		KRF15A-03	KRF25A-03	KRF40A-03
Designed capacity	L/min	235/280	405/480	575/685
Speed 2	Single-phase	1450/1730		
	Three-phase	1450/1730		
Ultimate vacuum	kPa	84 or more / 86 or more	86 or more / 90 or more	
Continuous operative Vacuum (V type)	Recommended range 3	60 or less		
	Maximum value 4	75	80	
Continuous exhaust pressure(B type)	Recommended range 3	60 or less		
	Maximum value 4	70		
Continuous operative pressure (V·B type)	Recommended range 3	Total of vacuum level and exhaust pressure: 60kPa or lower		
	Maximum value 4	Total of vacuum level and exhaust pressure: 75	Total of vacuum level and exhaust pressure: 80	
Diameter of piping connection		Rc3/4		
Power supply 2, 5, 6	Single-phase	100V-50/60, 200V-50/60		
	Three-phase 200V spec	200V-50/60, 220V-60		
	Three-phase 400V spec	380V-50, 400V-50/60, 415V-50, 440V-60, 460V-60		
Motor	Single-phase	0.4 (4P)	0.75 (4P)	1.1 (4P)
	Three-phase 200V spec			
	Three-phase 400V spec			
Rated current 2	Single-phase	6.8/6.0 (100V-50/60Hz) 3.4/3.0 (200V-50/60Hz)	11.0/10.4 (100V-50/60Hz) 5.5/5.2 (200V-50/60Hz)	
	Three-phase 200V spec	2.3/2.0 (200V-50/60Hz) 2.0 (220V-60Hz)	3.8/3.4 (200V-50/60Hz) 3.4 (220V-60Hz)	5.3/5.2 (200V-50/60Hz) 5.2 (220V-60Hz)
	Three-phase 400V spec	1.1 (220V-50Hz) 1.1/1.0(400V-50/60Hz)	1.9 (380V-50Hz) 1.9/1.7(400V-50/60Hz)	2.7 (380V-50Hz) 2.7/2.5(400V-50/60Hz)
		1.1 (415V-50Hz) 1.0 (440V-60Hz) 1.0 (460V-60Hz)	1.9 (415V-50Hz) 1.7 (440V-60Hz) 1.7 (460V-60Hz)	2.7 (415V-50Hz) 2.5 (440V-60Hz) 2.5 (460V-60Hz)
Mass 2	Single-phase	21	32	
	Three-phase 200V spec	20	28	36
	Three-phase 400V spec			
Operation noise Single-phase 2	(V)	62/64	64/66	
	(B)	64/65	67/69	
Operation noise Three-phase 2	(V)	60/62	62/64	66/67
	(B)	64/65	65/67	68/70
Applicable environment	Installation site	Indoor		
	Permissible ambient temperature	0 to 40 deg.C		
	Suction air 7	"Normal temperature : 0 to 40 deg.C , Normal humidity : 65 ± 20% (JIS Z 8703) Conditions where there is no corrosive and explosive gas exist. Clean air without vapor and dew condensation, and less dirt and dust."		
	Altitude of installation	1000m or less		
	Pollution Degree 8	Pollution Degree 3 (Worse environment than normal environment)		
Overvoltage classification 8	Classification 3 (supply from the fixed wiring facility)			

*1 Only three-phase specification is complied with CE marking.

*2 Values shown are with our standard motor.

*3 Recommended range: The pump can exert its optimal performance (life, operation noise, etc.) under vacuum/pressure within this range.

Use the pump within the recommended range unless the higher vacuum/pressure is required.

*4 Maximum value: This is the upper vacuum/pressure limit for continuous operation of the pump.

Avoid operating the pump over the upper limit. Operation beyond this limit will shorten the working life and also may cause failure or accident.

*5 Allowable intermittent power supply voltage fluctuation range is ±10% of the specified voltage; allowable sustained supply voltage fluctuation range is ±5% of the specified voltage.

*6 Voltage specifications for motors other than our standard ones are according to power supply specifications shown on the motor name plates.

*7 Consult with your dealer if the product is used in extremely low humidity for adjustment. It may cause the malfunction of pump.

*8 Refer to IEC664-1.

Dimensional Outline Drawing

KRF15A-V-03, KRF15A-B-03

(unit : mm)

KRF15A-V-03

The controller and the inlet port can be attached to A, B, C, and D.

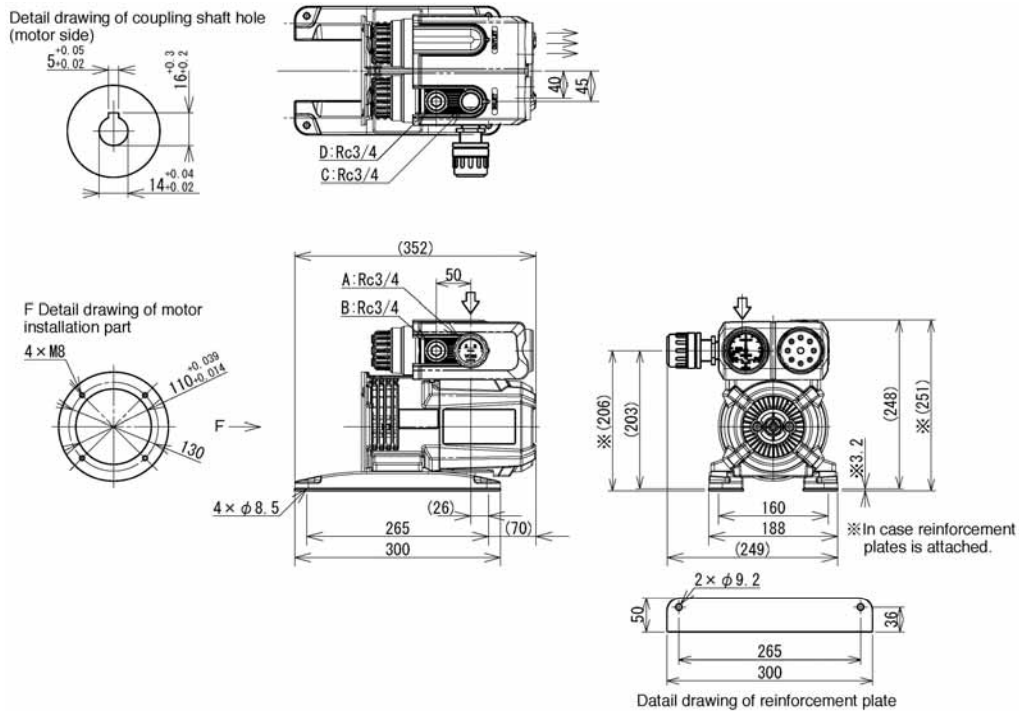

KRF15A-B-03

The controller and the inlet port can be attached to A, B, C, and D.
However, the outlet port can only be attached to A and C.

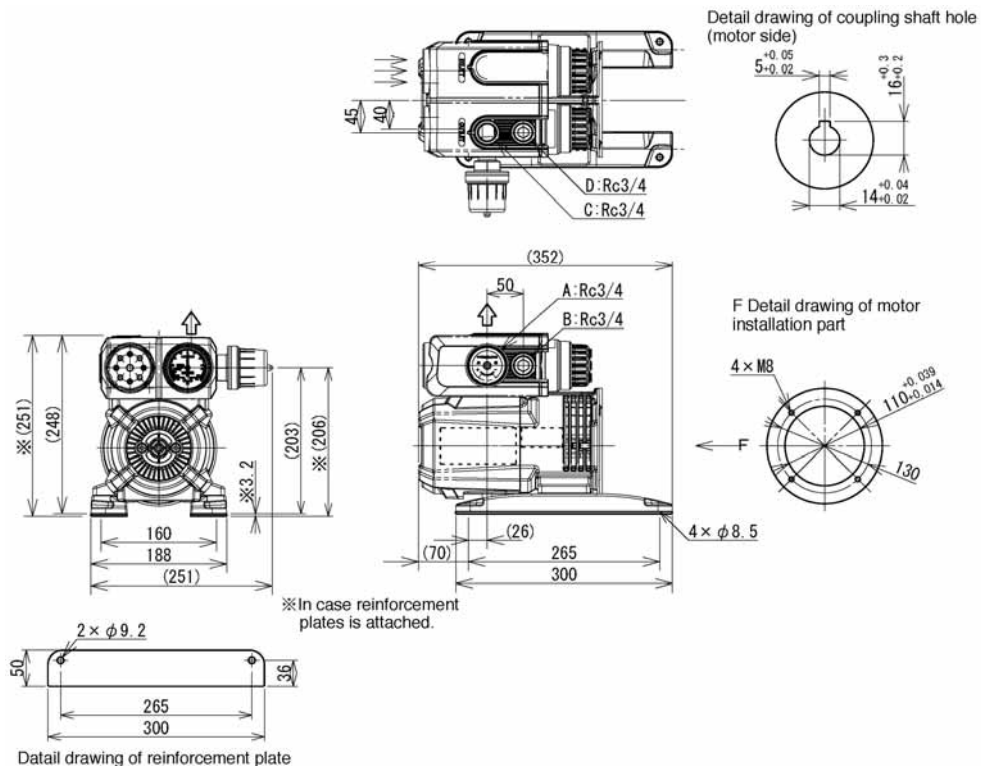

Dimensional Outline Drawing

KRF15A-VB-03

(unit : mm)

KRF15A-VB-03

The vacuum controller and the inlet port can be attached to A, B, C, and D.
The pressure controller can be attached to E, F, G, and H. However, the outlet port can only be attached to G and E.

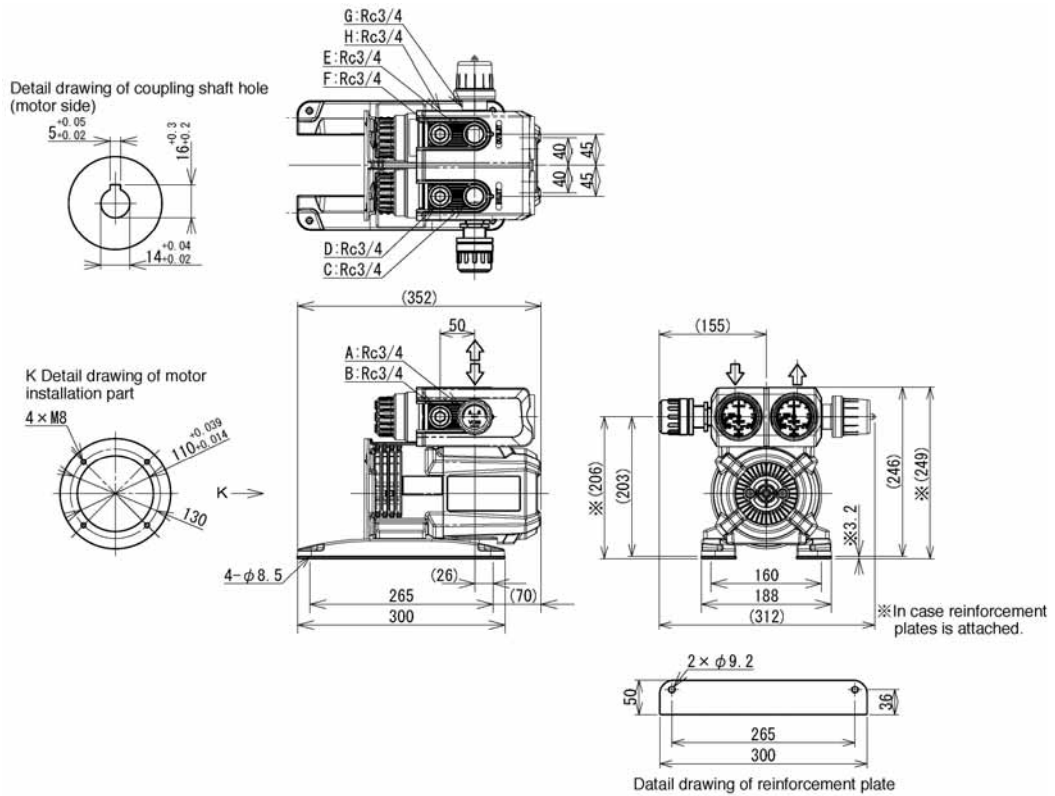

Dimensional Outline Drawing

KRF25A-V-03, KRF25A-B-03

(unit : mm)

KRF25A-V-03

The controller and the inlet port can be attached to A, B, C, and D.

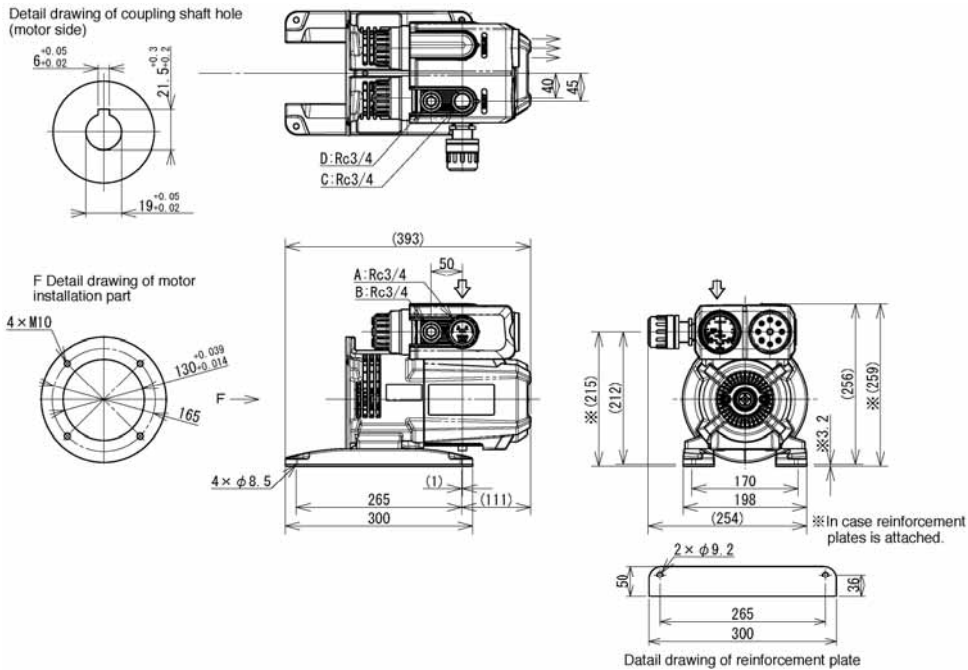

KRF25A-B-03

The controller and the inlet port can be attached to A, B, C, and D.
However, the outlet port can only be attached to A and C.

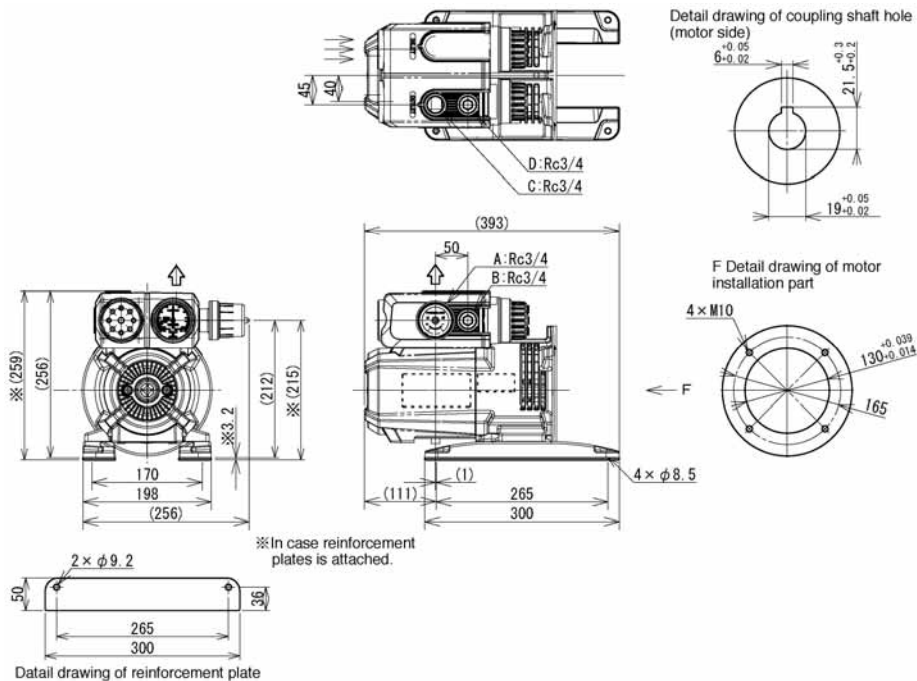

Dimensional Outline Drawing

KRF25A-VB-03

(unit : mm)

KRF25A-VB-03

The vacuum controller and the inlet port can be attached to A, B, C, and D.
The pressure controller can be attached to E, F, G, and H. However, the outlet port can only be attached to G and E.

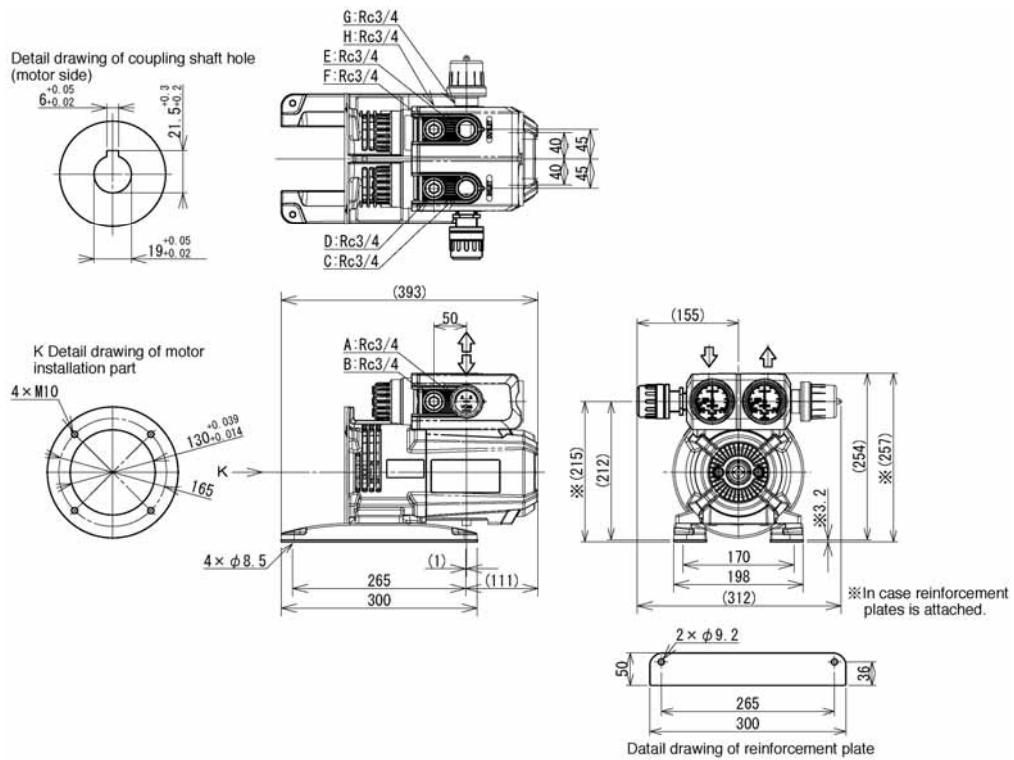

Dimensional Outline Drawing

KRF40A-V-03, KRF40A-B-03

(unit : mm)

KRF40A-V-03

The controller and the inlet port can be attached to A, B, C, and D.

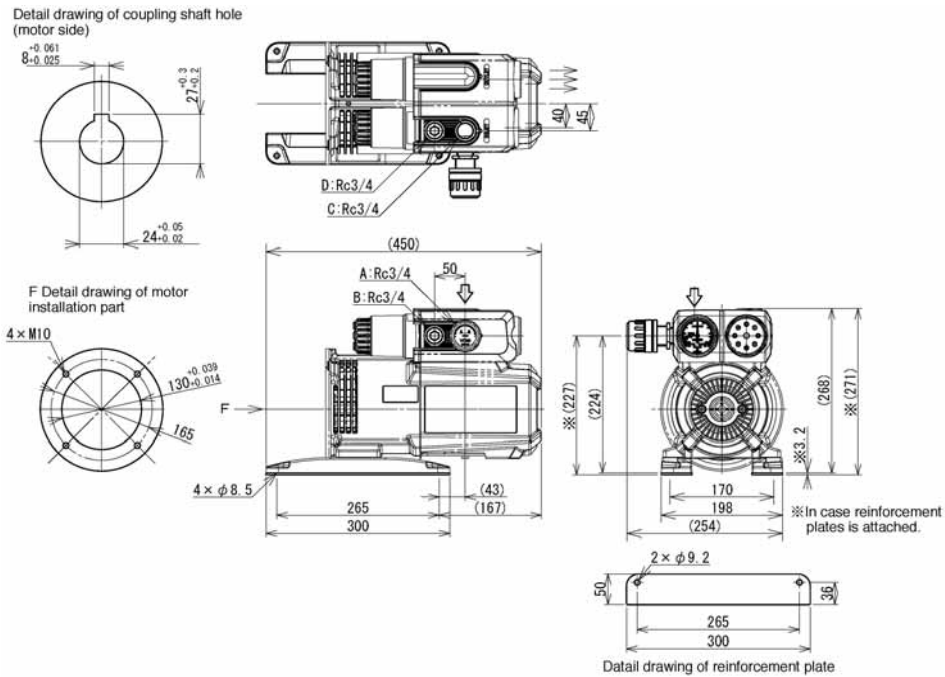

KRF40A-B-03

The controller and the inlet port can be attached to A, B, C, and D.
However, the outlet port can only be attached to A and C.

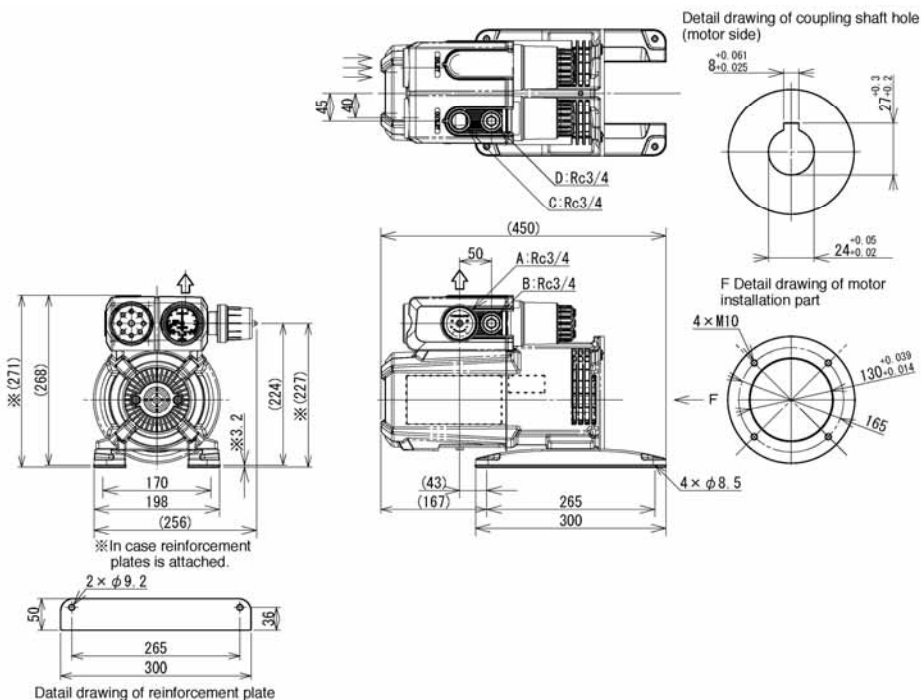

Dimensional Outline Drawing

KRF40A-VB-03

(unit : mm)

KRF40A-VB-03

The vacuum controller and the inlet port can be attached to A, B, C, and D.
The pressure controller can be attached to E, F, G, and H. However, the outlet port can only be attached to G and E.

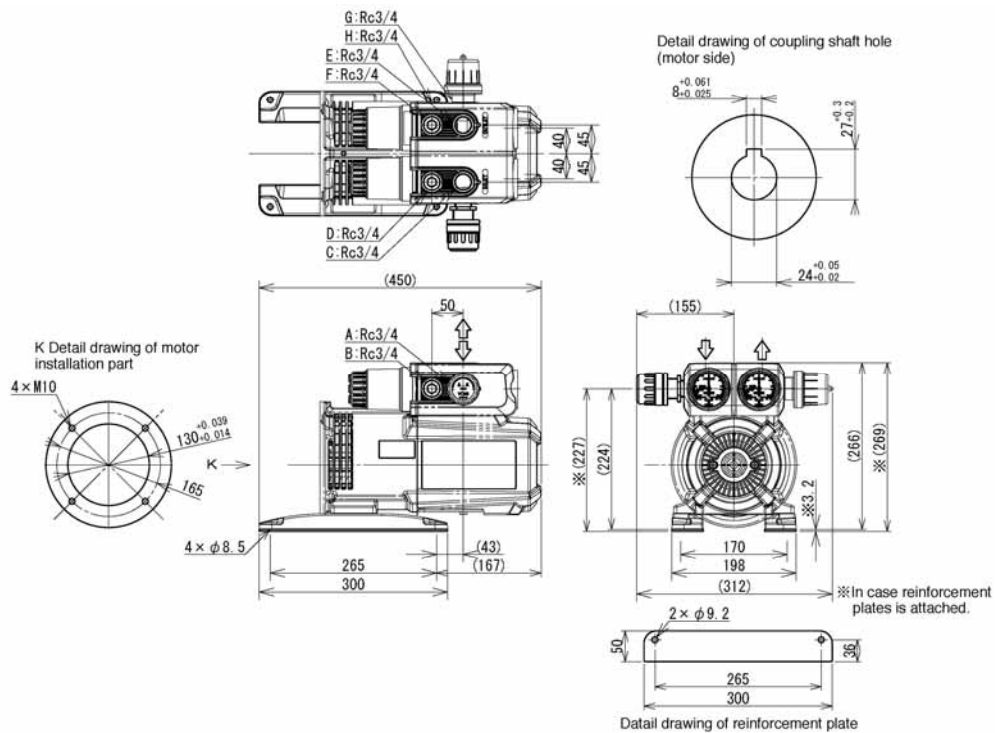



オリオン機械株式会社

http://www.orionkikai.co.jp

当社製品に関するお問合せ・資料請求は

営業統括部 TEL 026-245-1263 FAX 026-245-5358
〒382-8502 長野県須坂市大字幸高246
E-mail: sijo@orionkikai.co.jp

- 北海道地区統括 北海道オリオン株式会社 TEL 011-865-3666
- 東北地区統括 東北オリオン株式会社 TEL 022-284-0691
- 関東地区統括 東日本オリオン株式会社 TEL 03-3523-8881
- 甲信越地区統括 長野オリオン販売株式会社 TEL 026-248-2428
- 東海・北陸地区統括 中部オリオン株式会社 TEL 0586-76-1217
- 近畿・中四国地区統括 関西オリオン株式会社 TEL 06-6305-1414
- 九州地区統括 西日本オリオン株式会社 TEL 092-477-8480

本社・工場 〒382-8502 長野県須坂市大字幸高246
更 埴 工場 〒387-0007 長野県千曲市大字屋代1291
千 歳 工場 〒066-0077 北海道千歳市上長都1051-16

便利メモ（おぼえのため、記入されると便利です。）

お買いあげ日		製造番号	
販 売 店 名		店名	
		電話 () -	



ORION MACHINERY CO., LTD.

Head Office and Factory : No. 246 Kotaka, Suzaka-shi, Nagano-ken, 382-8502 Japan
Tel: +81-(26)-245-1230 Fax: +81-(26)-245-5424

☐ No.7867 '09.11.27 C DG