

FEATURES

- o Composite vane material for long life
- o Oil level sight glass
- o Vibraton isolators
- o Anti-suck back valve
- o Integral exhaust filters
- o TEFC high-efficiency tri-voltage motor (208-230-460V 50/60)
- o Wire mesh inlet screen



Airtech's L-Series rotary vane oil-flooded vacuum pump is a real workhorse. Reliability and durability are ensured by its simple design. Our L-Series Pump has integral exhaust filters, vibration isolators, and composite vane material which promotes longevity. The Airtech pump has an operating capacity range of 7-460 CFM while obtaining an end vacuum of 0.5 Torr.

PERFORMANCE CURVES

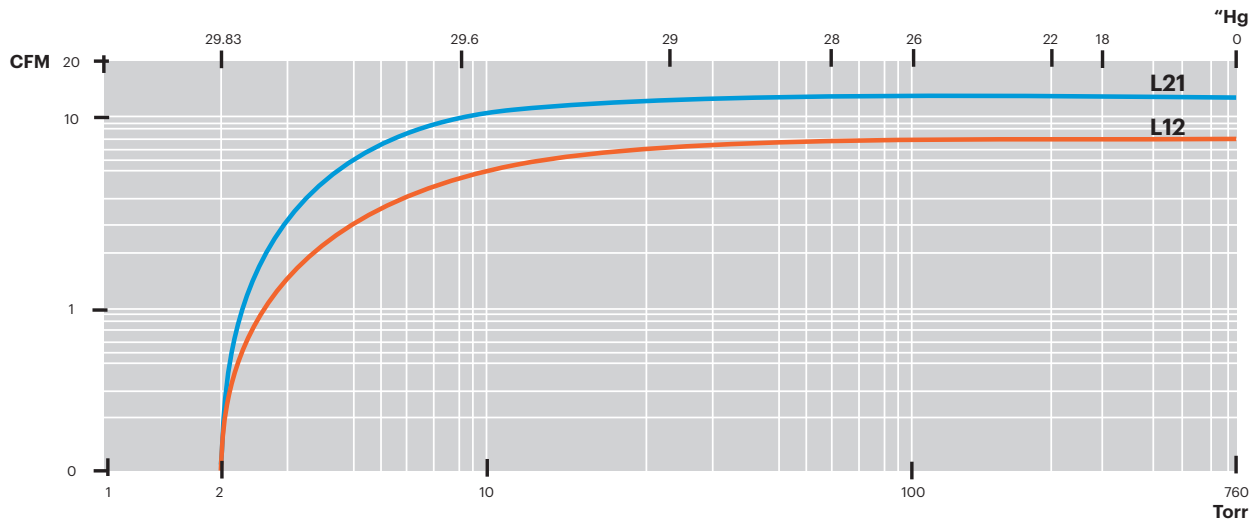

POWER CONSUMPTION

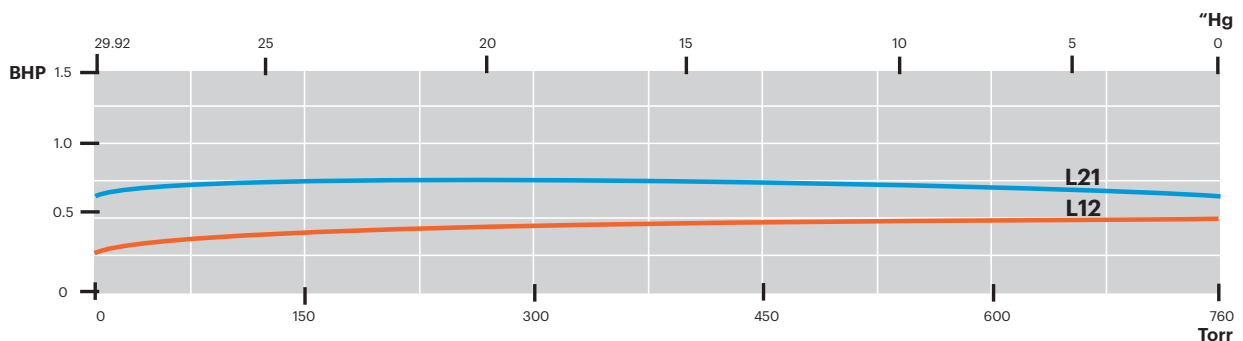

DIMENSIONS (INCHES)

Specifications are subject to change without notice. Please contact factory for specification updates.

L12

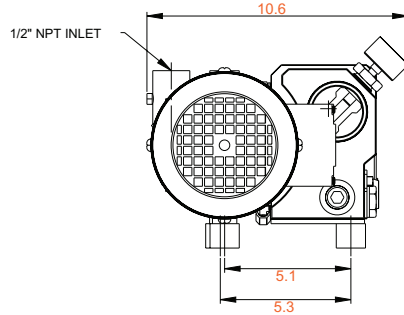

L21

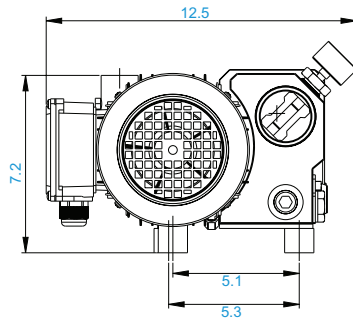

L12

L21

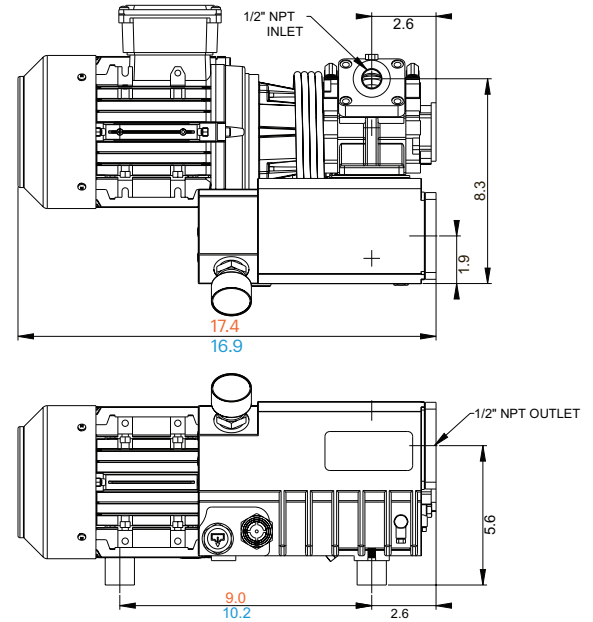

PERFORMANCE DATA

Model	L 12	L 21
Free Air Displacement [CFM]	7	15
Motor Capacity (HP)	0.75	1.0
Speed (RPM)	1725	3450
Sound Level [dB (A)]	59	62
End Vacuum (Torr)	2.0	2.0
Weight with motor (lbs.)	42	42
Oil Quantity (Qts.)	0.5	0.5

AIRTECH, INC.

RUTHERFORD, NJ 07070
 WWW.AIRTECHUSA.COM
 TEL: (888) 222-9940
 FAX: (201) 569-1696