

Features:

- Meets NFPA-99 applications
- Low annual maintenance cost
- Air cooled intercooler
- Sealed bearings
- Head unloaders
- On board cooling fan
- Low noise

Product Construction Features:

Cylinder Barrel:

Aluminum alloy material and deep cooling fin ensure quick heat dissipation. Special cylinder hardening treatment results in improved wear resistance.

Compression Ring and Guide Ring:

Compression/guide ring made from high grade PTFE providing low friction and self lubrication.

Gasket:

Graphite material not only for reliable sealing but also environmental friendly.

Suction and Discharge Valve Assy:

High efficiency, low noise valve design for long life and trouble-free operation.

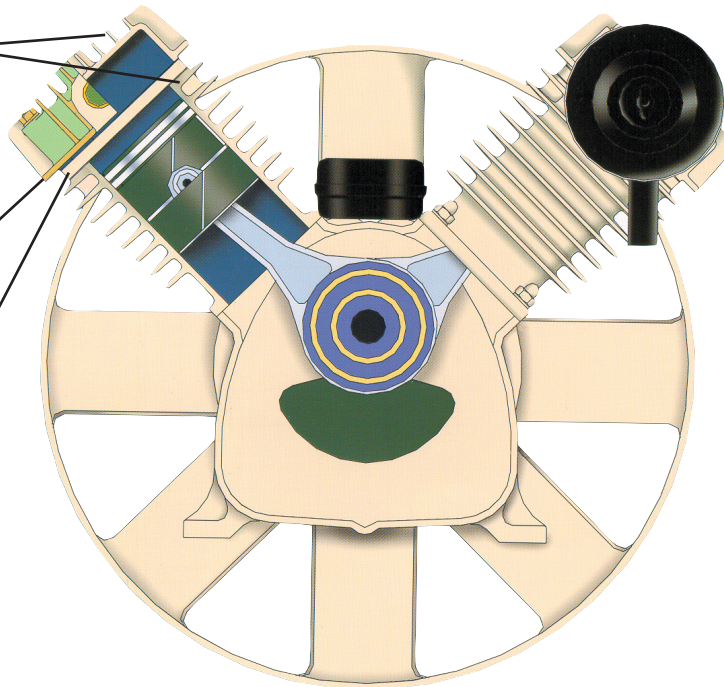

Cooling System:

Precision balanced cooling fan provides sufficient flow to control operating temperature. No additional cooling fan required.

Bearing:

Totally enclosed, packed with high temperature grease. Needle bearing in piston pin with rod made of low heat transmission alloy.

Crankshaft:

High grade ductile iron; hollow casting design with precise balance and machining. Effectively reducing running vibration and temperature.

Dimensions: (Inches)

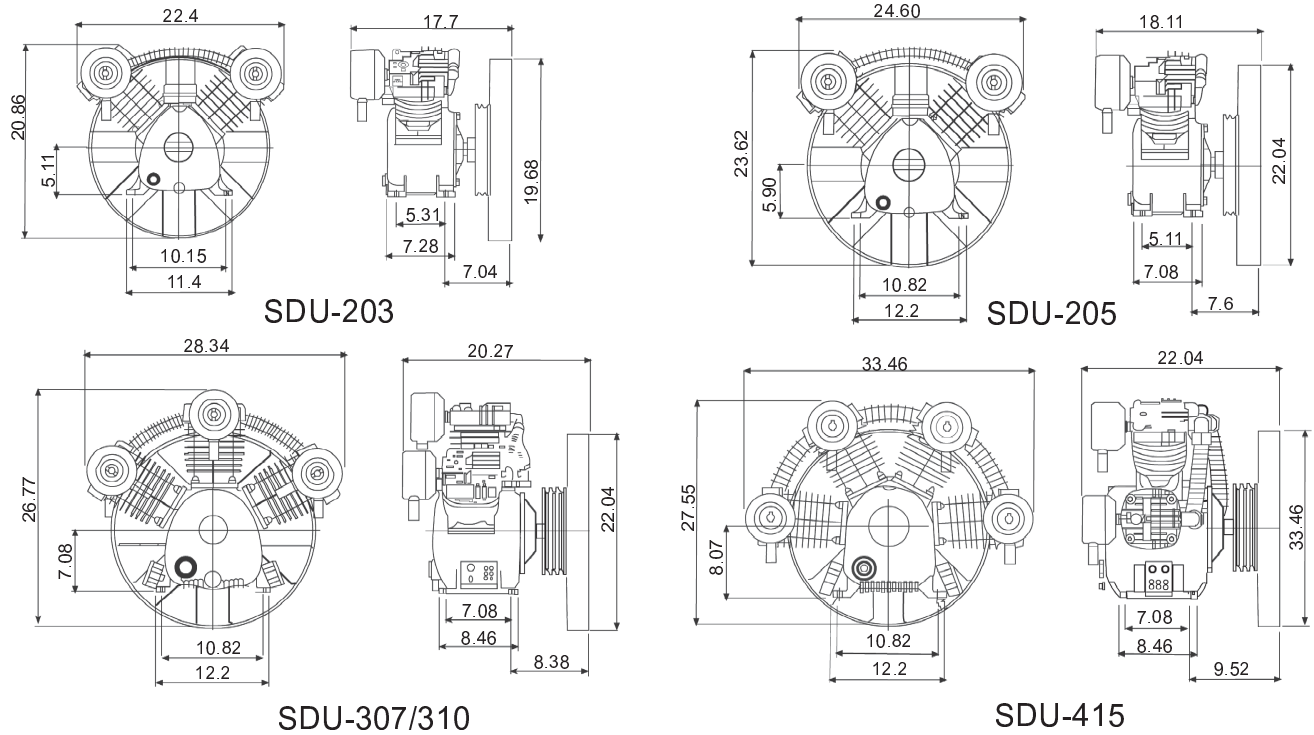

Specifications:

Model	SDU-203	SDU-205	SDU-307	SDU-310	SDU-415
HP	3	5	7.5	10	15
MAX PSIG	125	125	125	125	125
SCFM @ 50 PSIG	13	23	28	37.5	58
SCFM @ 100 PSIG	11.5	19.5	25.9	33.5	55
RPM @100 PSIG	700	700	700	850	950
Number/Cylinders	2	2	3	3	4