

AIRTECH[®] *VACUUM*

Installation
and
Operating Manual

OIL-LESS RECIPROCATING AIR COMPRESSOR

INSTALLATION & OPERATING MANUAL

OIL-LESS RECIPROCATING AIR COMPRESSOR

TABLE OF CONTENTS

	Page
1 DESCRIPTIONS	
A. GENERAL	2
B. PISTON & PISTON RINGS	2
C. HOURMETER	2
D. CONDENSATE DRAIN VALVE	2
2 INSTALLATION	
A. RECEIVING THE UNIT	2
B. INSTALLATION SITE	3
C. VENTILATION	3
D. WIRING	3
E. PIPING	3
F. SAFETY VALVES	4
3 OPERATION	
A. BEFORE START UP	4
B. START-UP AND OPERATION	4
4 MAINTENANCE SCHEDULE	5
5 TECHNICAL DRAWINGS	
A. DIMENSIONS	6
B. SPECIFICATIONS	6
C. SDU 203	
Parts Breakdown	7
Parts List	7
D. SDU 205	
Parts Breakdown	8
Parts List	8
E. SDU 307	
Parts Breakdown	9
Parts List	9
F. SDU 415	
Parts Breakdown	10
Parts List	10
6 WARRANTY	11

NOTE: THIS OPERATION AND MAINTENANCE MANUAL IS A GENERAL GUIDELINE FOR AIRTECH OILLESS RECIPROCATING AIR COMPRESSORS AND SHOULD BE USED IN CONJUNCTION WITH SPECIFIC MANUALS FOR THE SUPPLIED AIR COMPRESSOR ALONG WITH AS BUILT WIRING DIAGRAMS.

1 DESCRIPTIONS

A. GENERAL

The Airtech Oilless Reciprocating Air Compressor has advanced compressor technology through the development of a completely oilless unit. The Airtech Reciprocating Compressor is available in single stage models. Continuously lubricated, sealed bearings provide oil-free compressed air and long compressor life. The finned flywheel and temperature reducing aluminum alloy piston create lower operating temperatures.

B. PISTON AND PISTON RINGS

The Airtech oilless reciprocating compressor pistons are made of a high-strength aluminum alloy using the most advanced technology available. These heat reducing pistons eliminate the effect of excessive grease leakage at the wrist pin bearing. Teflon rings reduce wear and provide self lubrication.

C. HOURMETER

The hourmeter on the oilless compressor indicates the actual number of hours the unit has been in operation. The hourmeter is also used to determine maintenance and service timing. **An hour meter must be installed with every oilless compressor.**

D. CONDENSATE DRAIN VALVE

A condensate drain valve must be installed on any tank used to allow removal of the liquid which will collect during compressor operations

***NOTICE: Drain liquid from tank daily.**

2 INSTALLATION

A. RECEIVING THE UNIT

Immediately upon receipt of the oilless compressor, the unit should be inspected for any damage which may have occurred in shipment. The compressor nameplate should be checked to see if the unit is the correct model and voltage as ordered.

DANGER: Breathable Air Warning

This compressor/pump is NOT equipped and should NOT be used "as is" to supply breathing quality air. For any application or air for human consumption, you must fit the compressor/pump with suitable in-line safety and alarm equipment. This additional equipment is necessary to properly filter and purify the air to meet minimal specifications for Grade D breathing as described in Compressed Gas Association Commodity Specification G 7.1 - 1966, OSHA 29 CFR 1910. 134, and/or Canadian Standards Associations (CSA).

DISCLAIMER OF WARRANTIES - In the event the compressor/pump is used for the purpose of breathing air application and proper in-line safety and alarm equipment is not simultaneously used, existing warranties are void, and Airtech disclaims any liability whatsoever for any loss, personal injury or damage.

B. INSTALLATION SITE

1. The oilless compressor must be located in a clean, well lit and well ventilated area.
2. The area should be free of excessive dust, toxic or flammable gases and moisture.
3. Never install the compressor where the ambient temperature is higher than 105° F or where humidity is high.
4. Clearance must allow for safe, effective inspection and maintenance.

Above	24"
Drive belt side	12"
Other sides	20"

5. If necessary, use metal shims or leveling pads to level the compressor. Never use wood to shim the compressor.

C. VENTILATION

1. If the oilless compressor is located in a totally enclosed room, an exhaust fan with access to outside air must be installed.
2. Never restrict the cooling fan exhaust air.
3. Never locate the compressor where hot exhaust air from other heat generating units may be pulled into the unit.

D. WIRING

All electrical hook-ups must be performed by a qualified electrician. Installations must be in accordance with local and national electrical codes.

Use solderless terminals to connect the electric power source.

E. PIPING

1. Make sure the piping is lined up without being strained or twisted when assembling the piping for the compressor.
2. Appropriate expansion loops or bends should be installed at the compressor to avoid stresses caused by changes in hot and cold conditions.
3. Piping supports should be anchored separately from the compressor to reduce noise and vibration.
4. Never use any piping smaller than the compressor connection.

5. Use flexible hose to connect the outlet of the compressor to the piping so that the vibration of the compressor does not transfer to the piping.

F. SAFETY VALVES

Tank mounted compressors are shipped from the factory with safety valves installed in the tank manifold. The flow capacity of the safety valve is equal to or greater than the capacity of the compressor.

1. The pressure setting of the safety valve must be no higher than the maximum working pressure of the tank.
2. Safety valves should be placed ahead of any possible blockage point in the system, i.e. shutoff valve.
3. Avoid connecting the safety valve with any tubing or piping.
4. Manually operate the safety valve every six months to avoid sticking or freezing.

3 OPERATION

Airtech oilless single stage compressors operate at a maximum pressure of 125 PSIG. Compressor RPM's are established by Airtech based on horsepower and operating pressure.

A. BEFORE START UP

1. Make sure all safety warnings, labels and instructions have been read and understood before continuing.
2. Remove any shipping materials, brackets, etc.
3. Confirm that the electric power source and ground have been firmly connected.
4. Be sure all pressure connections are tight.
5. Check to be certain all safety relief valves, etc., are correctly installed.
6. Check that all fuses, circuit breakers, etc., are the proper size.
7. Make sure the inlet filter is properly installed.
8. Confirm that the drain valve is closed.
9. Visually check the rotation of the compressor pump. If the rotation is incorrect, have a qualified electrician correct the motor wiring.

B. START-UP AND OPERATION

1. Follow all the procedures under "Before start-up" before attempting operation of the compressor.

2. Switch the electric source breaker on.
3. Open the tank discharge valve completely.
4. Check that the compressor operates without excessive vibration, unusual noises or leaks.
5. Close the discharge valve completely.
6. Check the discharge pressure. Also, make sure the air pressure rises to the designated pressure setting by checking the discharge pressure gauge.
7. Check the operation of the pressure switch or the pilot valve for continuous run units by opening the stop valve and confirming the compressor starts or reloads as pressure drops.

***NOTICE: If the compressor rotates in reverse for more than five seconds when the compressor is turned OFF, the check valve needs to be cleaned or replaced.**

Switch the breaker OFF if the compressor is not to be used for a long period of time.

***NOTICE: Units are equipped with head unloaders for continuous operation.**

4 MAINTENANCE SCHEDULE

Item	Action Needed	Operating Hours						Remarks
		500	2500	5000	10,000	15,000	20,000	
Tank	Drain moisture	Daily	2500					
Inlet Air Filter	Replace	●	▲	(Every 2,500 hours or less)				
Blower Fan	Clean			●	●	●	●	
Compressor Fins	Clean		●	(Every 2,500 hours or less)				
Bearings	Replace				●	●	▲	
Compression Rings	Replace				▲		▲	
Wrist Pin Bearing	Regrease				▲		▲	
Piston Set	Replace				▲		▲	
Unloader Spring	Replace (continuous operating pumps only)			▲	▲	▲	▲	
V-belt	Inspect, replace	*Note 3	●	▲	▲	▲	▲	
Pressure Switch	Confirm operation				●		●	
Magnetic Starter	Inspect				●		●	Replace if contact points deteriorated
Safety Valve	Confirm operation		●	(Every 2,500 hours or less)				
Pressure Gauge	Inspect		●	(Every 2,500 hours or less)				

- Inspect
- ▲ Replace

NOTES:

1. Inspect and perform maintenance periodically according to maintenance schedule.
2. The maintenance schedule relates to the normal operating conditions. If the circumstances and load condition are adverse, shorten the cycle time and do maintenance accordingly.
3. * The tension of the V-belt should be adjusted during the initial stage and inspected every 1,500 hours afterwards. Proper belt tension for 3/4 to 3 HP units is 12 lbs./5" deflection; for 5 to 20 HP units, 16 lbs./5" deflection.

Dimensions: (Inches)

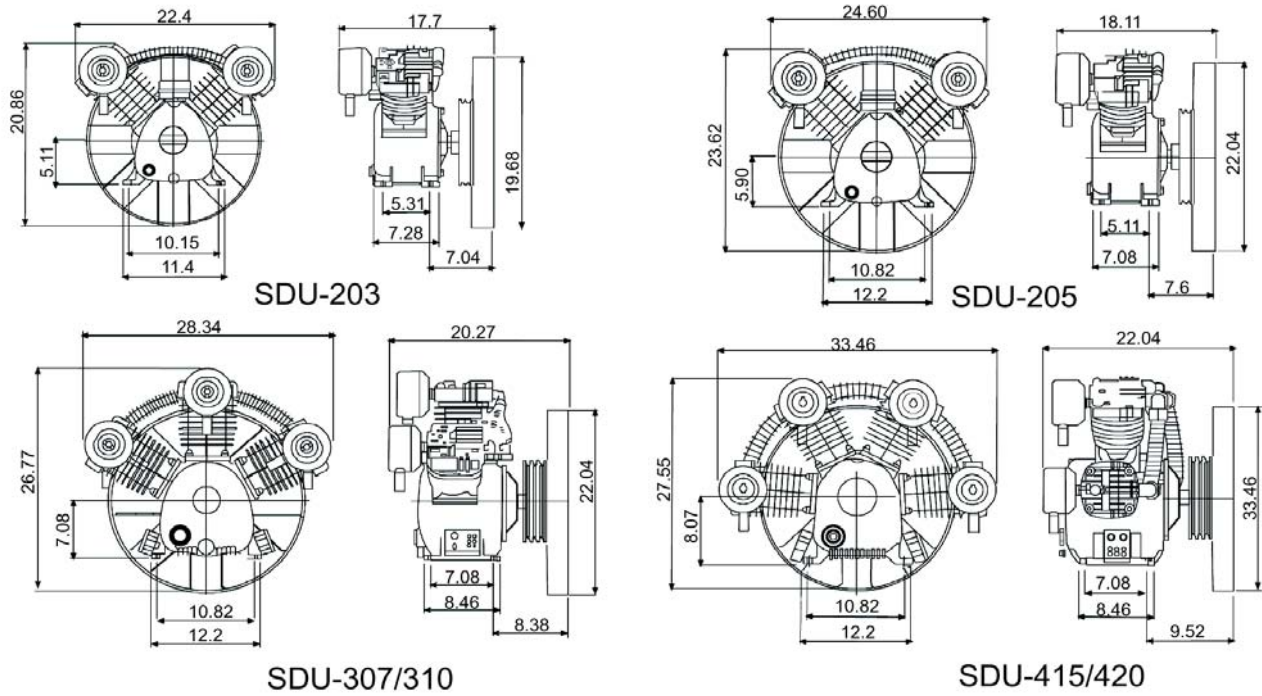

Specifications:

Model	SDU-203	SDU-205	SDU-307	SDU-310	SDU-415	SDU-420
HP	3	5	7.5	10	15	20
MAX PSIG	125	125	125	125	125	125
SCFM @ 50 PSIG	13	23	28	37.5	58	72
SCFM @ 100 PSIG	11.5	19.5	25.9	33.5	55	68
RPM @100 PSIG	700	700	700	850	950	1140
Number/Cylinders	2	2	3	3	4	4

SDU-203 (COMPRESSOR BODY)

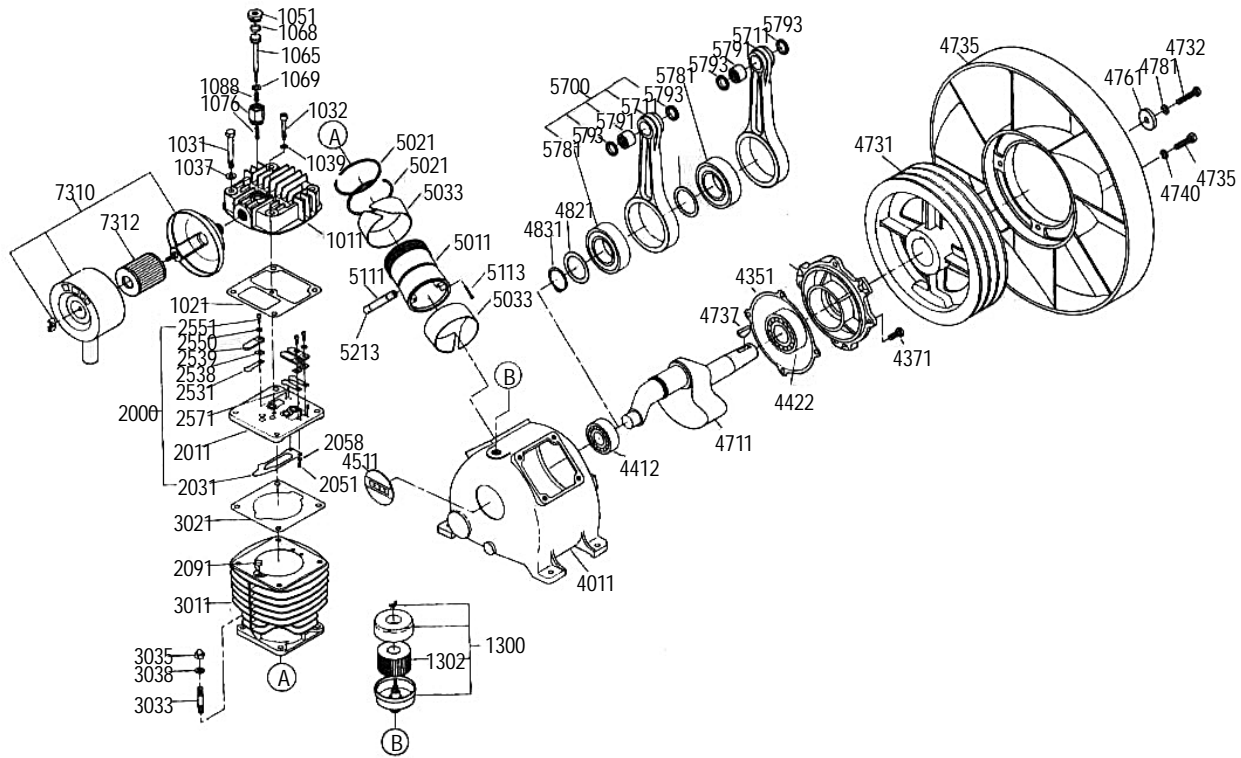

DESCRIPTION

Pos.	SDU 203
1011	Cylinder Head
1021	Head Packing
1031	Set blot
1032	Set blot
1037	Spring washer
1039	Spring washer
1051	Unloading nut
1065	Unloading piston
1068	O-ring (I)
1069	O-ring (II)
1076	Unloading seat
1087	Unloading spring (I)
1088	Unloading spring (II)
1300	Breathing assembly
1302	Breathing element
2000	Valve assembly
2011	Inlet valve seat
2031	Inlet valve plate
2051	Set bolt
2058	Spring washer
2091	Inlet cushion packing
2531	Outlet valve plate

Pos.	SDU 203
2538	Outlet set plate
2539	Outlet cushion plate
2551	Set bolt
2558	Spring washer
2571	Spring pin
3011	Cylinder
3021	Cylinder packing
3033	Set bolt
3035	Set nut
3038	Spring washer
4011	Crankcase
4321	Bearing case
4351	Bearing case packing
4371	Set bolt
4412	Front bearing
4422	Rear bearing
4511	Front cover
4711	Crank shaft
4731	Fly wheel
4732	Set bolt
4735	Fan
4736	Set bolt

Pos.	SDU 203
4737	Flywheel key
4740	Spring washer
4761	Thrust washer
4781	Spring washer
4821	Stop washer
4824	Rod washer
4831	Snap ring
5011	Piston
5021	Compression ring
5033	Guide ring
5111	Piston pin
5113	Set bolt
5213	Piston pin bushing
5700	Connecting rod assembly
5711	Connecting rod assembly
5781	Crank pin bearing
5791	Piston pin bearing
5793	Oil seal
7310	Filter assembly
7312	Filter element

SDU-205 (COMPRESSOR BODY)

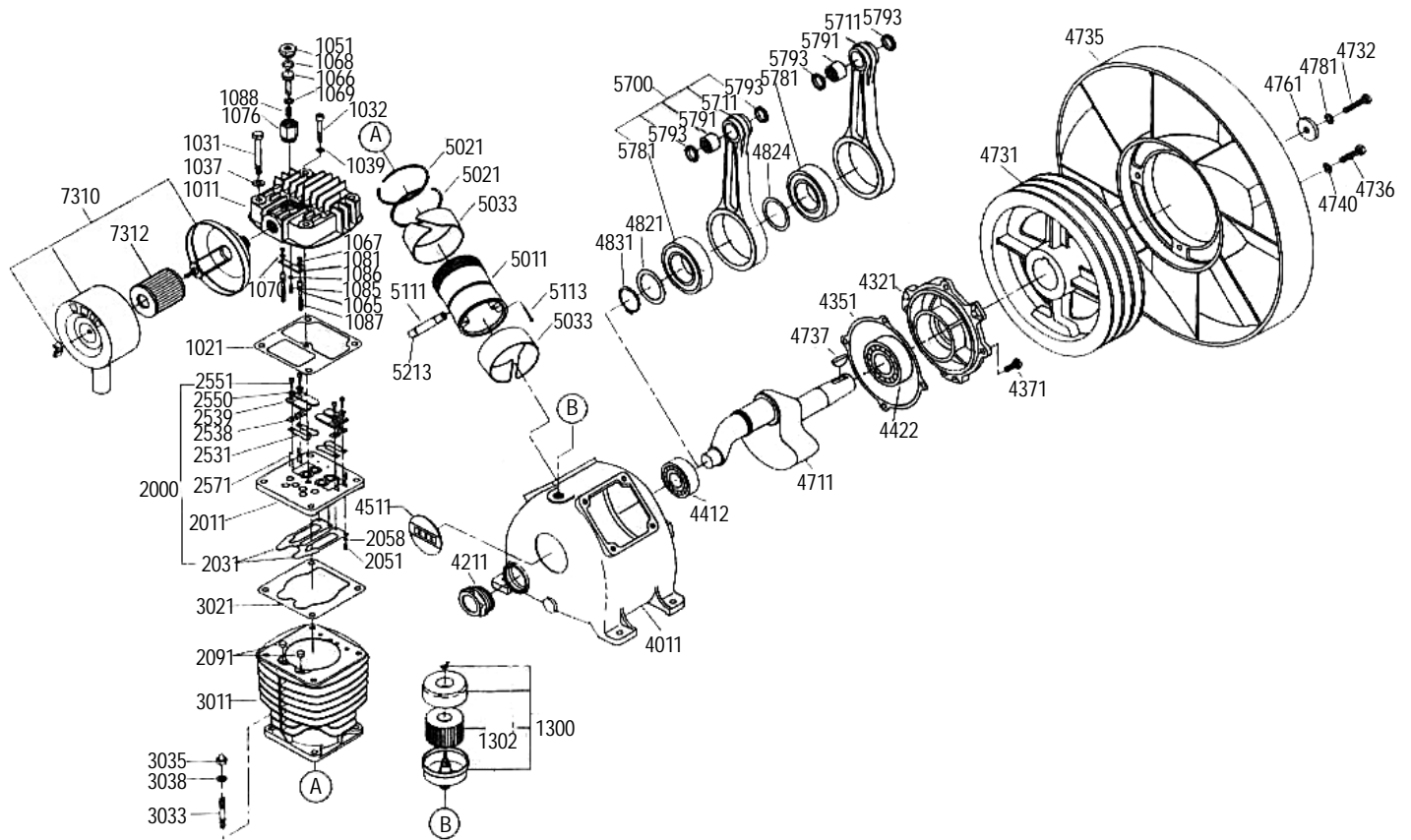

DESCRIPTION

Pos.	SDU 205
1011	Cylinder Head
1021	Head Packing
1031	Set blot
1032	Set blot
1037	Spring washer
1039	Spring washer
1051	Unloading nut
1065	Unloading piston (I)
1066	Unloading piston (II)
1067	Set bolt
1068	O-ring (I)
1069	O-ring (II)
1070	Spring washer
1076	Unloading seat
1081	Unloading fork
1085	Set bolt
1086	Spring washer
1087	Unloading spring (I)
1088	Unloading spring (II)
1300	Breathing assembly
1302	Breathing element
2000	Valve assembly
2011	Inlet valve seat
2031	Inlet valve plate

Pos.	SDU 205
2051	Set bolt
2058	Spring washer
2091	Inlet cushion packing
2531	Outlet valve plate
2538	Outlet set plate
2539	Outlet cushion plate
2551	Set bolt
2558	Spring washer
2571	Spring pin
3011	Cylinder
3021	Cylinder packing
3033	Set bolt
3035	Set nut
3038	Spring washer
4011	Crankcase
4211	Oil gauge
4321	Bearing case
4351	Bearing case packing
4371	Set bolt
4412	Front bearing
4422	Rear bearing
4511	Front cover
4711	Crank shaft
4731	Fly wheel

Pos.	SDU 205
4732	Set bolt
4735	Fan
4736	Set bolt
4737	Flywheel key
4740	Spring washer
4761	Thrust washer
4781	Spring washer
4821	Stop washer
4824	Rod washer
4831	Snap ring
5011	Piston
5021	Compression ring
5033	Guide ring
5111	Piston pin
5113	Set bolt
5213	Piston pin bushing
5700	Connecting rod assembly
5711	Connecting rod
5781	Crank pin bearing
5791	Piston pin bearing
5793	Oil seal
7310	Filter assembly
7312	Filter element

SDU-307

(COMPRESSOR BODY)

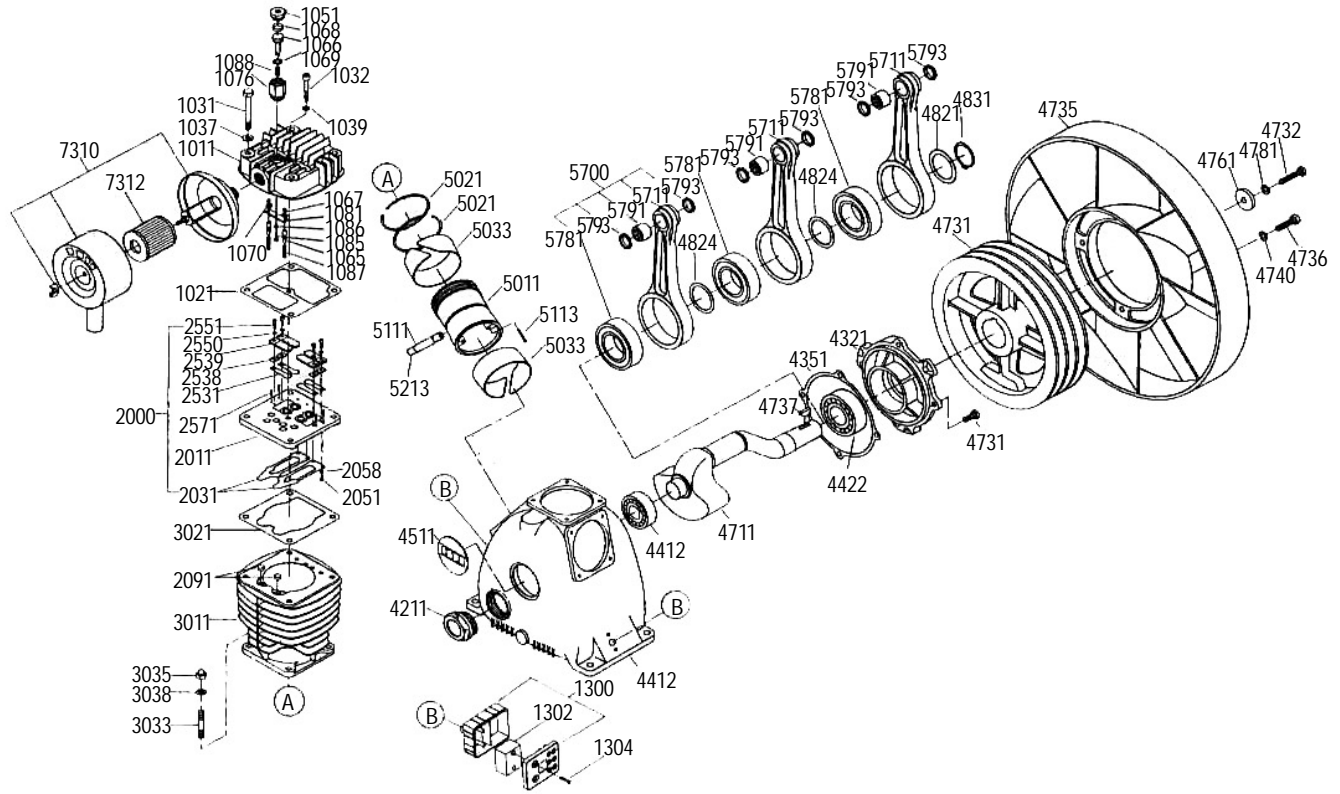

DESCRIPTION

Pos.	SDU 307
1011	Cylinder Head
1021	Head Packing
1031	Set blot
1032	Set blot
1037	Spring washer
1039	Spring washer
1051	Unloading nut
1065	Unloading piston (I)
1066	Unloading piston (II)
1067	Set bolt
1068	O-ring (I)
1069	O-ring (II)
1070	Spring washer
1076	Unloading seat
1081	Unloading fork
1085	Set bolt
1086	Spring washer
1087	Unloading spring (I)
1088	Unloading spring (II)
1300	Breathing assembly
1302	Breathing element
1304	Set bolt
2000	Valve assembly
2011	Inlet valve seat

Pos.	SDU 307
2031	Inlet valve plate
2051	Set bolt
2058	Spring washer
2091	Inlet cushion packing
2531	Outlet valve plate
2538	Outlet set plate
2539	Outlet cushion plate
2551	Set bolt
2558	Spring washer
2571	Spring pin
3011	Cylinder
3021	Cylinder packing
3033	Set bolt
3035	Set nut
3038	Spring washer
4011	Crankcase
4211	Oil gauge
4321	Bearing case
4351	Bearing case packing
4371	Set bolt
4412	Front bearing
4422	Rear bearing
4511	Front cover
4711	Crank shaft

Pos.	SDU 307
4731	Flywheel
4732	Set bolt
4735	Fan
4736	Set bolt
4737	Flywheel key
4740	Spring washer
4761	Thrust washer
4781	Spring washer
4821	Stop washer
4824	Rod washer
4831	Snap ring
5011	Piston
5021	Compression ring
5033	Guide ring
5111	Piston pin
5113	Set bolt
5213	Piston pin bushing
5700	Connecting rod assembly
5711	Connecting rod
5781	Crank pin bearing
5791	Piston pin bearing
5793	Oil seal
7310	Filter assembly
7312	Filter element

SDU-415

(COMPRESSOR BODY)

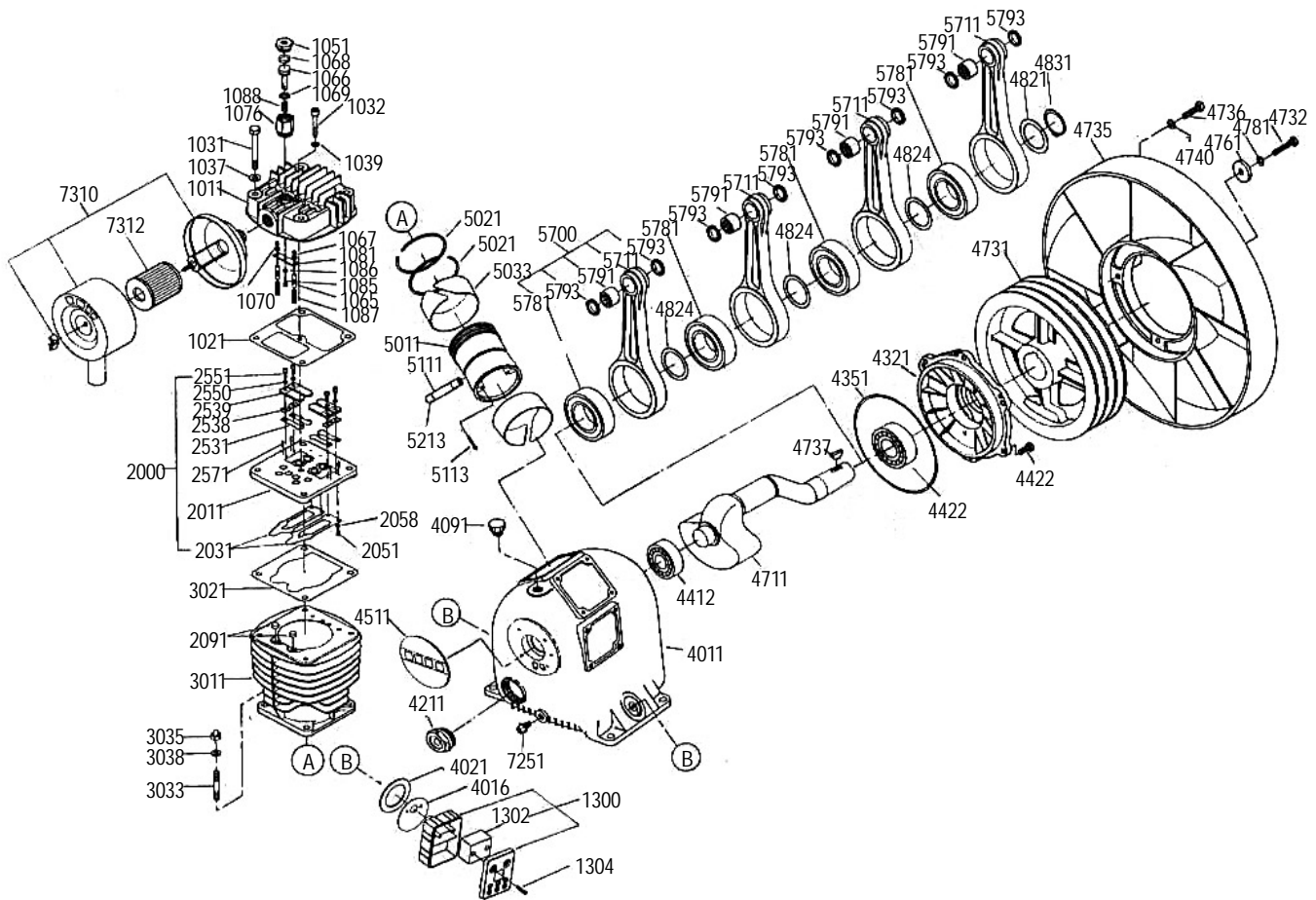

DESCRIPTION

Pos.	SDU 415
1011	Cylinder Head
1021	Head Packing
1031	Set blot
1032	Set blot
1037	Spring washer
1039	Spring washer
1051	Unloading nut
1065	Unloading piston (I)
1066	Unloading piston (II)
1067	Set bolt
1068	O-ring (I)
1069	O-ring (II)
1070	Spring washer
1076	Unloading seat
1081	Unloading fork
1085	Set bolt
1086	Spring washer
1087	Unloading spring (I)
1088	Unloading spring (II)
1300	Breathing assembly
1302	Breathing element
1304	Set bolt
2000	Valve assembly
2011	Inlet valve seat
2031	Inlet valve plate

Pos.	SDU 415
2051	Set bolt
2058	Spring washer
2091	Inlet cushion packing
2531	Outlet valve plate
2538	Outlet set plate
2539	Outlet cushion plate
2551	Set bolt
2558	Spring washer
2571	Spring pin
3011	Cylinder
3021	Cylinder packing
3033	Set bolt
3035	Set nut
3038	Spring washer
4011	Crankcase
4016	Side cover
4021	Side cover packing
4211	Oil gauge
4321	Bearing case
4351	Bearing case packing
4371	Set bolt
4412	Front bearing
4422	Rear bearing
4511	Front cover
4711	Crank shaft

Pos.	SDU 415
4731	Flywheel
4732	Set bolt
4735	Fan
4736	Set bolt
4737	Flywheel key
4740	Spring washer
4761	Thrust washer
4781	Spring washer
4821	Stop washer
4824	Rod washer
4831	Snap ring
5011	Piston
5021	Compression ring
5033	Guide ring
5111	Piston pin
5113	Set bolt
5213	Piston pin bushing
5700	Connecting rod assembly
5711	Connecting rod
5781	Crank pin bearing
5791	Piston pin bearing
5793	Oil seal
7310	Filter assembly
7312	Filter element

AIRTECH, INC.

System Warranty Policy

WARRANTY PERIOD

- A. New Airtech system, installed and maintained according to manufacturers recommendation, will be warranted against defects in material and workmanship for a period of two (2) years from the date of shipment from the factory.
- B. An extension of a warranty period will require written approval from Airtech and may require and inspection of the equipment by an Airtech representative. The cost for extending a warranty period will be determined at the time of the request.

WARRANTY STATUS

- A. Before proceeding with any warranty service, the selling distributor or the authorized Airtech service agent must first contact Airtech to (a) verify that the equipment is within the warranty period, (b) verify that the repair service provided is covered under warranty and (c) to initiate the Warranty Claim Form number.
- B. Final approval of all warranty service claims and credits will be determined by Airtech.
- C. It is the responsibility of the selling distributor to start-up the Airtech system and insure proper operation.

WARRANTY RESPONSIBILITY

- A. Responsibility for warranty service belongs to the selling distributor or the authorized Airtech service agent.
- B. Only authorized Airtech service agents will be compensated for performing warranty service work.

WARRANTY LIMITATIONS AND EXCLUSIONS

- A. The obligation of Airtech is limited under this warranty to repair or replace without charge, F.O.B. factory, any part that has proven to have an original manufactured defect.
- B. This warranty shall not apply to any equipment which has been subjected to misuse, neglect or accident: nor shall it apply to any equipment which has been repaired or altered by any person not authorized by Airtech.
- C. Components and/or accessories manufactured by other vendors (such as motors, etc.) will be warranted by the original manufacturer. The customer may be required to take the defective part to that manufacturer's authorized repair facility for replacement or repair.
- D. The maximum allowable warranty repair cost must not exceed 50% of the normal distributor cost of a replacement unit unless written authorization is obtained from Airtech.

- E. In the event of a warranty equipment replacement, the warranty on the replaced part shall not exceed the time remaining on the original parts warranty period.
- F. The effect of normal wear and tear, corrosion or oxidation are excluded from this warranty.
- G. Airtech will only pay warranty labor charges when the service performed satisfactorily corrects the problem.
- H. The following list of conditions are viewed as the responsibility of the end user or selling distributor and are not covered under warranty:
 - 1. Improper installation (including location) of:
 - a. piping
 - b. electrical wiring or voltage supply
 - c. extreme environmental conditions
 - 2. Any incidental damage.
 - 3. Instructions of any type concerning Airtech equipment.
 - 4. Adjustments including switches, controls, belts, tightening bolts, etc...
 - 5. Improper operation.
 - 6. Maintenance or normal wear items such as air or oil filter lubricants.
 - 7. Overtime premium.
 - 8. Rental equipment or lost production.

REIMBURSEMENT FOR WARRANTY SERVICE WORK

- A. Reimbursement for warranty service work provided will be as follows:
 - \$40.00 per labor hour
 - \$0.40 per mile
- B. Parts – The cost of parts used from the distributor's stock will be credited at the normal distributor cost. Any part needed for warranty repair may be ordered from Airtech with an accompanying purchase order. This order will receive priority handling and will be invoiced and credited back on the Warranty Claim Form. All parts which were replaced under warranty must be returned to Airtech freight prepaid, with the appropriate Warranty Claim Form number clearly marked on the box and packing slip.

FILING A WARRANTY CLAIM

- A. The Airtech Warranty Claim Form must be filled out with all information requested before any consideration can be given to the claim.
- B. Attach a copy of the Authorized Service Agent's work order to the form.
- C. Submit the Warranty Claim Form within 60 days of the equipment failure date in order to receive warranty consideration.

AIRTECH[®]
VACUUM

301 Veterans Boulevard
Rutherford, NJ 07070
Tel: 1 888 222 9940
Fax: 201 569 1696
airtech@airtechusa.com

AIRTECH[®] SOUTH
VACUUM

2121 Newmarket Pkwy. Suite 110
Marietta, GA 30067
Tel: 770 690 0700
Fax: 770 690 0709
airtechsouth@airtechusa.com

AIRTECH[®] WEST
VACUUM

42 Digital Drive #9
Novato, CA 94949
Tel: 415 382 9000
Fax: 415 382 9700
airtechwest@airtechusa.com

AIRTECH[®] CHINA
VACUUM

2nd Building,
Jiangbian Second Industrial Park
Songgang Town, Bao'an District
Shenzhen, China
Tel: +86 755 81730991(Ext.8018)
Fax: +86 755 81730986
www.airtechchina.com

AIRTECH[®] EUROPE

Pfaffenpfad 5
D-97440 Werneck
Germany
Tel: +49 9722 943 96 0
Fax: +49 9722 943 96 29
www.airtecheu.com

AIRTECH[®] ASIA
VACUUM

Pfaffenpfad 5
D-97440 Werneck
Germany
Tel: +49 9722 943 96 0
Fax: +49 9722 943 96 29
www.airtechas.com