



Installation

and

Operating Manual

Oil-Less Piston Type Vacuum Pumps and Compressors

Models **HP40** Through **HP200**

INSTALLATION & OPERATING MANUAL

HP SERIES OIL-LESS PISTON TYPE VACUUM PUMPS AND COMPRESSORS Models **HP40** through **HP200**

Please read this manual before operating the vacuum pump

TABLE OF CONTENTS

- 1.0 INSTALLATION**
 - 1.1 UNPACKING
 - 1.2 LOCATION
 - 1.3 ELECTRICAL CONNECTIONS

- 2.0 OPERATION**

- 3.0 WARRANTY**

- 4.0 TROUBLESHOOTING**

INSTALLATION AND OPERATING MANUAL

This manual is written to cover HP series oil-less piston type vacuum pumps. The model number will appear as follows: HP followed by 40,90,120,140,or 200, followed by V, VH, or C.

Please identify the model number and serial number when ordering parts.

1.0 INSTALLATION

1.1 Unpacking

Inspect the box and pump carefully for any signs of damage incurred in transit. Since all pumps are ordinarily shipped F.O.B. from our factory or regional warehouse, such damage is the normal responsibility of the carrier and should be reported to them.

1.2 Installation

Screw the four rubber feet into the nuts located on the bottom of pump to reduce vibration. Install the pump in a horizontal position on a level surface so that the pump is evenly supported on its rubber feet. The pump must be installed in a dry, well ventilated place, which is as free of dust as possible. Leave 12-18" of access around the pump to allow proper cooling. Adequate ventilation must also be provided for the fans, radiator, and motor.

Remove plastic plugs from the inlet and outlet port before operating pump. Pump may be damaged if plugs are not removed.

Never operate the pump outdoors in the rain or near an open flame.

1.3 Electrical Connection

Check the voltage and frequency on the identification plate before starting the electrical power of motor.

The standard thermal protector will trip automatically if the maximum permitted temperature is exceeded. The pump will re-start automatically when it is cooled down.

2.0 OPERATION

Only atmospheric air is permitted as working media. Do not evacuate corrosive liquid or vapor with the pump.

Dirt will damage the pump so always use a suitable inlet filter. After the pump has been stopped, air will gradually seep back into the evacuated spaces. If this is undesirable, it will be necessary to fit a check valve in front of the inlet port.

The noise of air flow can be reduced with a silencer on the outlet port.

The standard pump can not start against a full vacuum. Contact Airtech for an alternate vacuum pump designed to meet the demand of starting against full vacuum.

Improper disassembly or repair will damage the pump. Only qualified personnel should do repair service.

The pump is maintenance-free. Do not lubricate any of the parts with oil, grease, or petroleum products nor clean with acids, caustics, or chlorinated solvents at any time. This can affect the service life of the pump.

3.0 WARRANTY

When the pump is properly installed and operated under normal conditions of use, it is warranted by Airtech Inc. for one year. Warranty claims of defective pumps must be asserted within one year from the date of delivery.

4.0 TROUBLESHOOTING

PROBLEM

Pump will not start

POSSIBLE CAUSE

- A. No main power supply
- B. Low voltage
- C. Capacitor defective
- D. Full vacuum in piping system
- E. Motor defective
- F. Thermal protector switch on

REMEDY

- A. Check main power
- B. Check voltage
- C. Check capacitor, replace if necessary
- D. Install a vacuum break valve or order pump with re-start movement
- E. Return to factory for repair
- F. Wait for pump to cool down, pump will re-start automatically

PROBLEM

Pump does not reach ultimate pressure

POSSIBLE CAUSE

- A. Pipes, hoses, or connection leaking
- B. Inlet filter or exhaust filter is dirty
- C. Cylinder or cup seal defective
- D. Plate valve defective
- E. Vacuum gauge defective
- F. Pump is too small

REMEDY

- A. Check and seal or replace
- B. Clean filter cartridge or replace necessary
- C. Replace cylinder or cup seal
- D. Replace plate valve
- E. Use correct size vacuum gauge
- F. Utilize larger pump

PROBLEM

Pump is excessively noisy

POSSIBLE CAUSE

- A. Damaged bearings
- B. Plate valve defective
- C. Cylinder or cup seal defective
- D. Vibration being transferred to enclosure

REMEDY

- A. Return to factory for repair
- B. Replace plate valve
- C. Replace cylinder or cup seal
- D. Use suitable anti-vibration mounting

PROBLEM

Pump gets too hot

POSSIBLE CAUSE

- A. Cooling air supply is obstructed
- B. Ambient temperature is too high
- C. Process air is too hot

REMEDY

- A. Provide for adequate ventilation
- B. Relocate pump to area where ambient temperature is less than 40° C
- C. Add cooling provisions for the process air so that the inlet temperature is less than 30° C (max depends on vacuum)

HP40 Parts List

Pos.#.	Qty.	Description	Pos.#.	Qty.	Description
1	1	Stator	23	1	Valve Flapper
2	1	Rotor	24	1	Upper Valve Fixed Strip
3	1	Housing	25	1	Screw
4	2	Shockproof Foot	26	1	Valve O-ring
5	2	Bearing	27	1	Head Cover
6	2	Piston Rod	28	4	Screw
7	1	Bearing	29	1	PP Plug
8	1	Circle Eccentric	30	1	Silencer base
9	1	Fan Fixed Clamp	31	2	Nut
10	1	Cooling Fan	32	2	Spring Washer
11	1	Cooling Fan Cover	33	1	Silencer Top Cover
12	4	Screw	34	1	Silencer cotton
13	1	Screw	35	1	Silencer Cap
14	1	Piston Ring	36	1	Screw
15	1	Piston Round Plate	37	1	Piston Plate O-Ring
16	2	Screw	38	1	Connecting Tube
17	1	Cylinder	39	1	Capacitor Holder
18	2	Screw	40	2	Screw
19	1	Lower Valve Fixed Strip	41	2	Tie
20	1	Valve Flapper	42	1	Capacitor
21	1	Cylinder O-ring	43	4	Spring Washer
22	1	Valve Plate	44	4	Bolt Housing

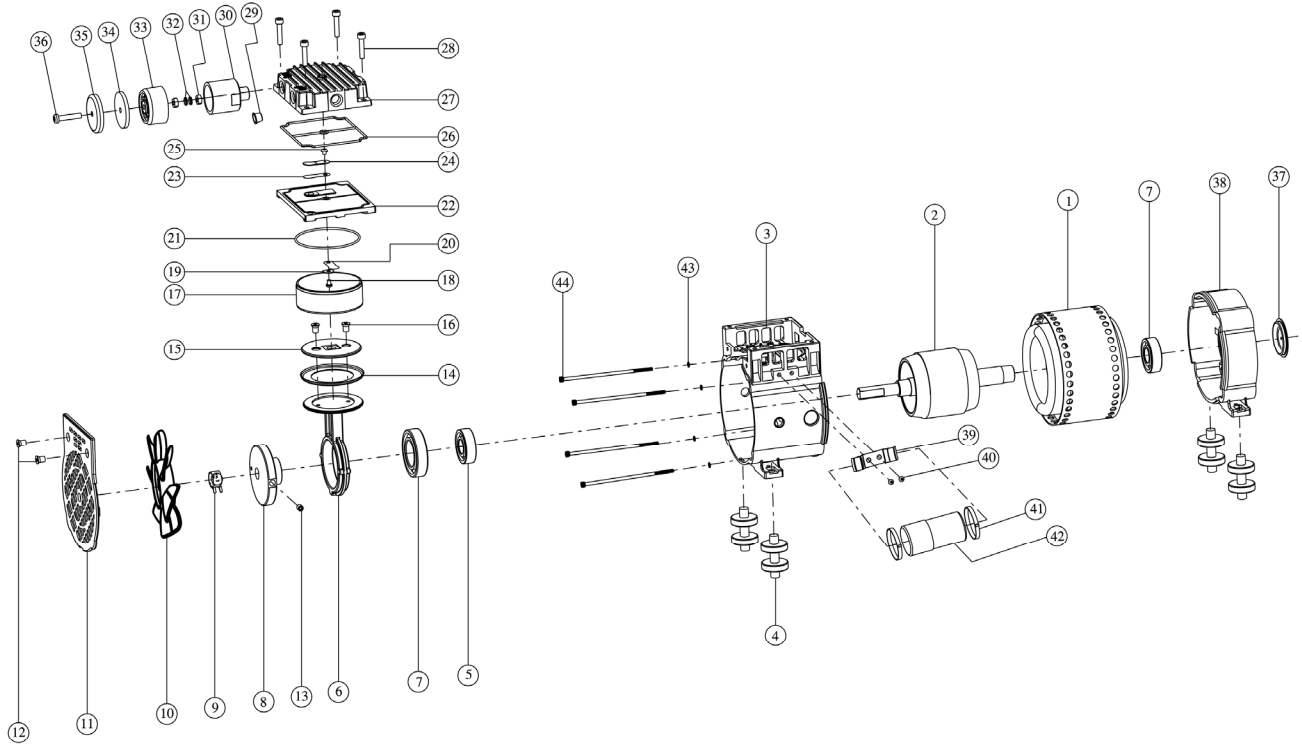

HP90 – HP200 Parts List

Pos.#.	Qty.	Description	Pos.#.	Qty.	Description
1	1	Stator	23	2	Valve Flapper
2	1	Rotor	24	2	Upper Valve Fixed Strip
3	2	Housing	25	2	Screw
4	4	Shockproof Foot	26	2	Valve O-ring
5	2	Bearing	27	2	Head Cover
6	2	Piston Rod	28	8	Screw
7	2	Bearing	29	1	PP Plug
8	2	Circle Eccentric	30	1	Silencer base
9	2	Fan Fixed Clamp	31	2	Nut
10	2	Cooling Fan	32	2	Spring Washer
11	2	Cooling Fan Cover	33	1	Silencer Top Cover
12	4	Screw	34	1	Silencer cotton
13	2	Screw	35	1	Silencer Cap
14	2	Piston Ring	36	1	Screw
15	2	Piston Round Plate	37	8	Cover
16	4	Screw	38	2	Back Casing
17	2	Cylinder	39	1	Capacitor Holder
18	2	Screw	40	2	Screw
19	2	Lower Valve Fixed Strip	41	2	Tie
20	2	Valve Flapper	42	1	Capacitor
21	2	Cylinder O-ring	43	4	Spring Washer
22	2	Valve Plate	44	4	Bolt Housing

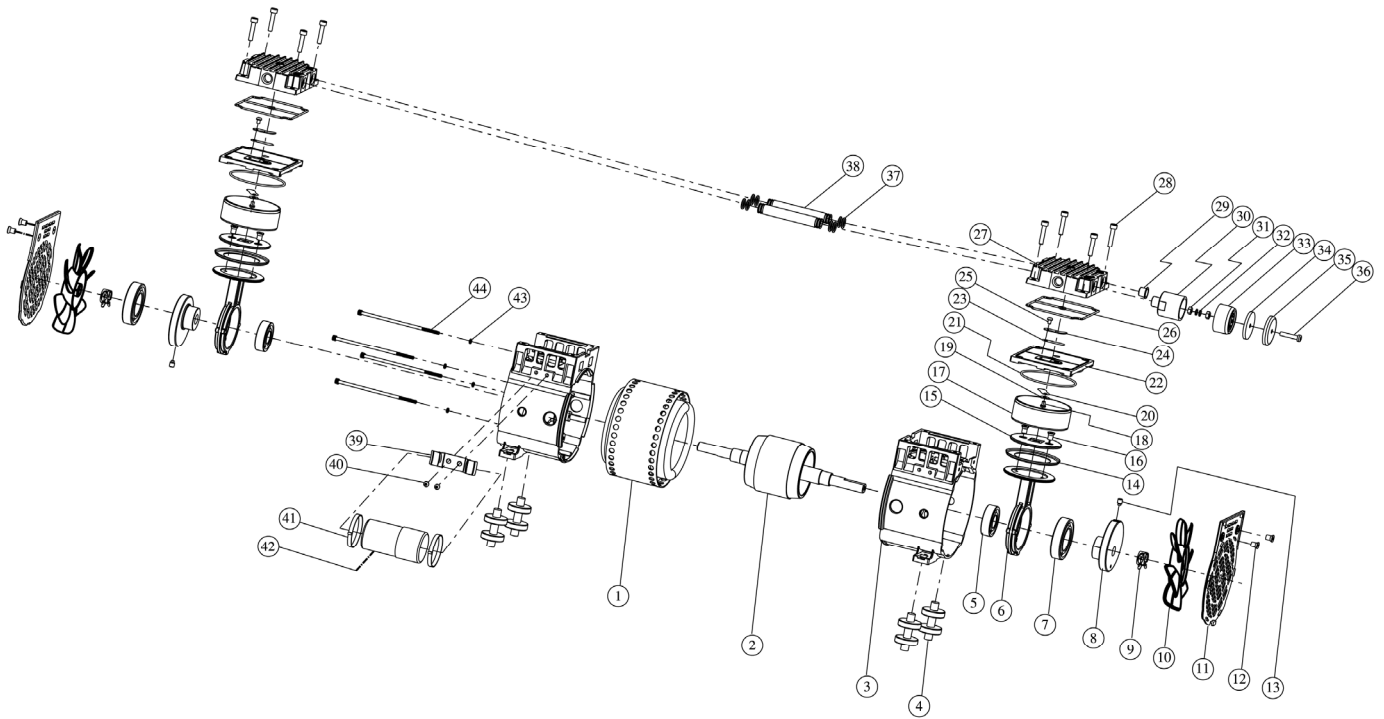

AIRTECH[®]
VACUUM

301 Veterans Boulevard
Rutherford, NJ 07070
Tel: 1 888 222 9940
Fax: 201 569 1696
airtech@airtechusa.com

AIRTECH[®] SOUTH
VACUUM

2121 Newmarket Pkwy. Suite 110
Marietta, GA 30067
Tel: 770 690 0700
Fax: 770 690 0709
airtechsouth@airtechusa.com

AIRTECH[®] WEST
VACUUM

42 Digital Drive #9
Novato, CA 94949
Tel: 415 382 9000
Fax: 415 382 9700
airtechwest@airtechusa.com

AIRTECH[®] CHINA
VACUUM

2nd Building,
Jiangbian Second Industrial Park
Songgang Town, Bao'an District
Shenzhen, China
Tel: +86 755 81730991(Ext.8018)
Fax: +86 755 81730986
www.airtechchina.com

AIRTECH[®] EUROPE

Pfaffenpfad 5
D-97440 Werneck
Germany
Tel: +49 9722 943 96 0
Fax: +49 9722 943 96 29
www.airtecheu.com

AIRTECH[®] ASIA
VACUUM

Pfaffenpfad 5
D-97440 Werneck
Germany
Tel: +49 9722 943 96 0
Fax: +49 9722 943 96 29
www.airtechas.com